

SFT 880 Operation Manual

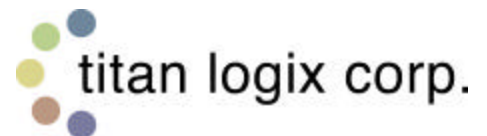

Head Office
4130 – 93 Street
Edmonton, AB, Canada T6E 5P5

Saskatchewan Office
Box 460, 103 Cenaiko Street
Lampman, SK Canada S0C 1N0

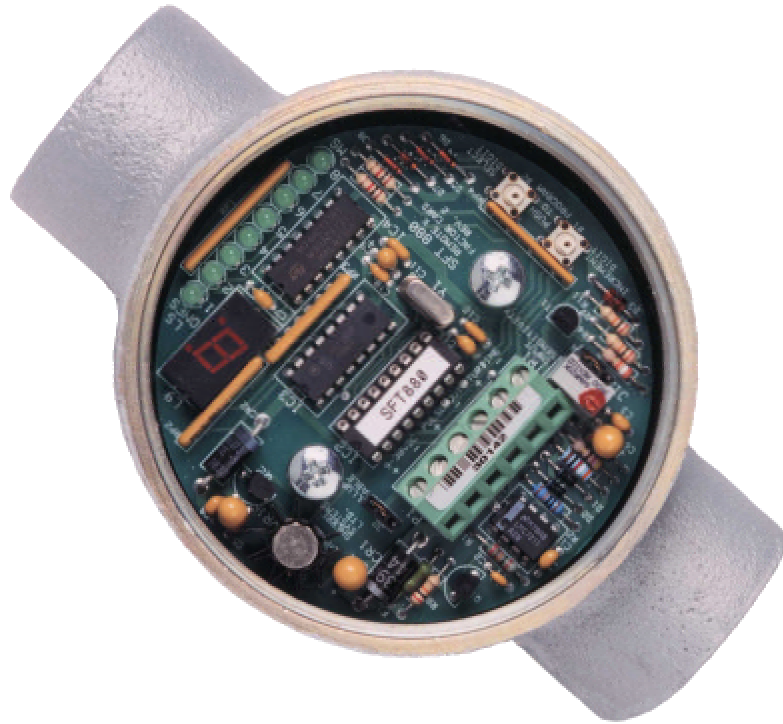

Manufactured in Canada

Toll Free 1-877-462-4085

Web Site www.titanlogix.com

E-Mail sales@titanlogix.com



instrumentation solutions that just make sense.

At Titan Logix Corp., we endeavour to design equipment that is simple to use and reliable in its operation, with the aim of satisfying our customers needs.

Titan Logix Corp. fields of expertise include:

- Level and Flow Measurement
- Transport Instruments
- Burner and Combustion
- Communication and Control System Integration and
- Drilling Fluid Monitoring

We have been designing and manufacturing electronic equipment since 1980. Titan Logix Corp. unites four companies – each a leader in different segments of the oil and gas industry:

- Titan Technologies
- Nagy Burner Control (NBC)
- Sherrex Systems
- Alberta Industrial Technologies (AIT)

Titan Logix Corp. sells and markets through subsidiaries, distributors and representatives. Through continuous improvement we are striving to provide our customers with first-rate sales information, engineering assistance and after sales support.

For more details on our products and services, please contact us at 1-877-462-4085 and we will provide you with a listing of the offices or representatives nearest you.

Titan Logix Corp.

SFT880

WARRANTY STATEMENT

WARRANTY: Titan Logix Corp. warrants all equipment of its own manufacture to be free of defects in material and workmanship for a period of twelve (12) months from date of shipment. Titan Logix Corp.'s sole obligation hereunder shall be expressly limited to repair or exchange free of charge, F.O.B. Edmonton, Alberta, Canada, of such defective equipment (alternatively, Titan Logix Corp. will, at its option, refund the purchase price). Titan Logix Corp.'s obligation under this warranty is limited to the above and does not apply to exchange or repairs which are required as a result of improper installation, misuse, maladjustment, abnormal operating conditions, or lack of routine maintenance. Nor does the warranty include the furnishing of service for maintenance or problems arising from the foregoing causes. No claims for labour, installation, removal, transportation, or other expenses will be recognized. Notwithstanding any stipulation of the purchaser to the contrary, all other obligations, representations, warranties and conditions, express or implied, statutory or otherwise, including any implied warranties or conditions of merchantability, quality or fitness are hereby excluded and, Titan Logix Corp. shall not be liable for any loss, cost or damages, of any kind whatsoever, whether consequential, indirect, special or otherwise, arising out of or in connection with the equipment or any defect therein, even if caused by the negligence of, Titan Logix Corp., its employees or agents. The provisions hereof relating to the warranty and limitations hereon and limitation of liability shall continue to be enforceable between the parties notwithstanding termination of the within agreement for any reason including fundamental breach. Equipment not of, Titan Logix Corp. manufacture will carry the vendor's or manufacturer's standard warranty.

©2002 Titan Logix Corp.

Table of Contents

| | |
|--|-----------|
| Introduction | 4 |
| About This Manual..... | 4 |
| About the SFT880..... | 5 |
| Main Features..... | 5 |
| Installation | 6 |
| Environmental..... | 6 |
| Outline..... | 7 |
| Mounting..... | 7 |
| Interconnection..... | 8 |
| Turbine Input..... | 9 |
| Pulse Output..... | 10 |
| Power..... | 11 |
| Setting the Pulse Output Level..... | 12 |
| Adjusting the Gain Sensitivity..... | 15 |
| Operation When Installed Correctly..... | 15 |
| Programming | 16 |
| K Factor | 17 |
| Output Pulse Width and Pulse State | 18 |
| Programming Example..... | 19 |
| Volume Conversion Factors | 22 |
| Troubleshooting..... | 24 |
| Specifications | 26 |

Introduction

About This Manual

This instruction manual provides information specific to the Titan Logix Corp. Division SFT880. Other peripheral equipment should be supplied with its own instruction manual and that manual should be referred to for proper operation of the peripheral equipment.

It is essential that this manual be read and understood for proper installation and operation of your SFT880.

This manual includes:

| | |
|-------------------------|--|
| <i>INTRODUCTION:</i> | Briefly describes the key features of the SFT880. |
| <i>INSTALLATION:</i> | Detailed description of mounting and wiring of external equipment. Also has description of normal operation. |
| <i>PROGRAMMING:</i> | Describes the method for programming the K factor, pulse width, and output pulse state. |
| <i>TROUBLESHOOTING:</i> | Describes several quick problem solving techniques. |
| <i>SPECIFICATIONS:</i> | Describes the physical and operational characteristics. |

About the SFT880

The SFT880 is an inexpensive interface between the low level pulses produced by a turbine and the higher level pulses required by a standard digital input. This allows the SFT880 to be connected to many different totalization devices from dedicated flow totalizers up to standard RTU and PLC inputs. The SFT 880 is designed with a user programmable K factor to allow the input signal to be divided into more useable volume measures, this allows for standard digital accumulators to act as more easily as a flow totalizer.

The wide range of input power, low current consumption, K factor, and explosion proof enclosure combine to make the SFT880 a highly versatile and inexpensive solution to turbine interface problems.

Please refer to the INSTALLATION section of this manual for directions on how to connect and set up The SFT880.

Main Features

| | |
|---------------|--|
| Enclosure: | CSA approved Class I, DIVISION I, GROUPS B, C, & D, NEMA 3 & 4. |
| Input/Output: | Turbine input from 0Hz to 4kHz at 15mVRMS to 30VRMS. Adjustable pulse input sensitivity for use in noisy environments. Pulse output at approximately the input supply voltage when using the internal pullup or open drain when using external pullup. Output frequency will depend on input frequency and K factor. |
| Reliability: | Built using industrial specified components to ensure long life and reliability even in harsh conditions. |
| Programming: | The SFT880 can be programmed by the user. The programmable features are K factor, (from 0 to 99 999 999), output pulse width (0.15mS, 25mS, 100mS, 500mS, 1S), and output pulse state (normally high or normally low). |

Installation

Installation should only be performed by qualified personnel, and in accordance with local governing regulations.

Environmental

Choose a mounting location suited to the SFT880 enclosure.

The ideal SFT880 mounting location is where the:

1. Turbine pickup is as close as possible.
2. Mounting surface has minimal vibration.
3. Ambient temperature is always within -40°C to $+70^{\circ}\text{C}$ (-40°F to $+158^{\circ}\text{F}$).
4. Cable lengths are minimal.
5. Terminal labeling is visible.

Avoid mounting locations where the SFT880 is:

- Vibrating.
- Close to high voltage/current runs, contactors, SCR control devices, or frequency inverters.

Outline

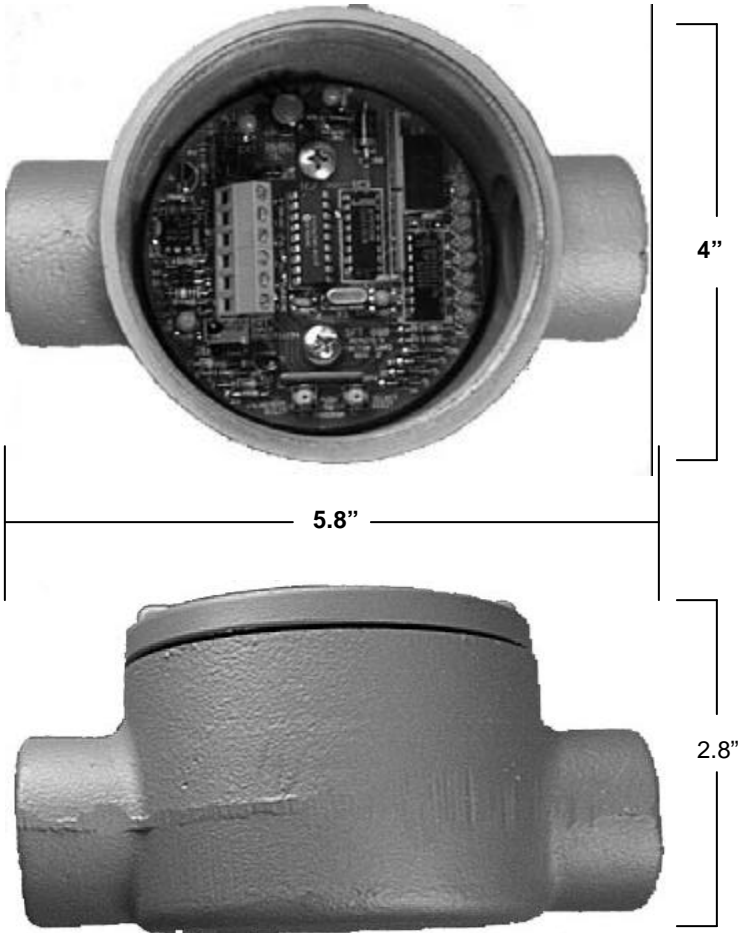

Mounting

The SFT880 has been designed to mount directly onto a **standard 1" threaded, rigid conduit or equivalent reducing fitting.**

Interconnection

Perform all wiring in accordance with local governing regulations.

Please refer to the diagram below for the location of the configuration jumpers and the I/O terminals on the SFT880.

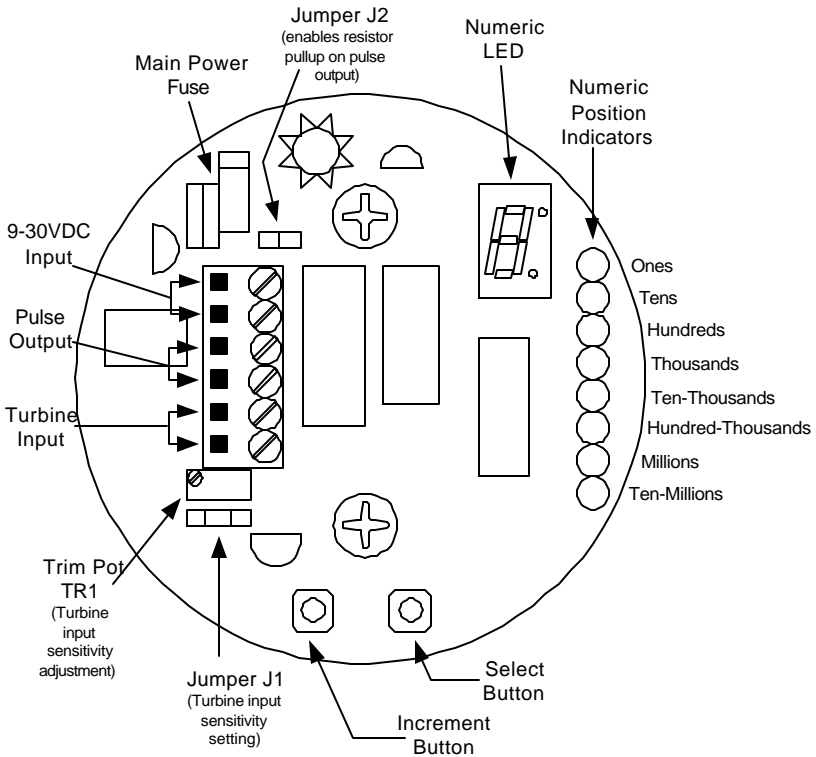

Turbine Input

The turbine input is a **non-polarized input**. To connect the magnetic pickup to the SFT880, bring the wires to terminals 5 and 6 of the terminal block (labeled TURBINE).

NOTE: To prevent improper operation and false input readings, the **SFT880** should be mounted as close as possible to the turbine's magnetic pickup.

If the SFT880 cannot be mounted close to the pickup, use shielded cable and connect the shield to Earth Ground at one end only.

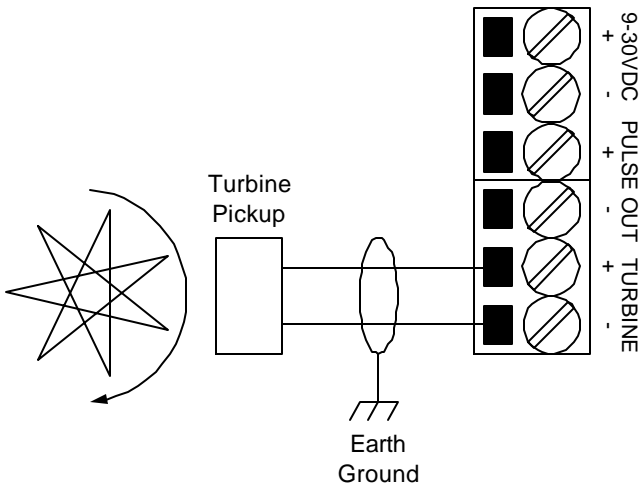

Pulse Output

The SFT880 has an open drain pulse output for connection to external monitoring equipment (eg. flow totalizer, PLC input, RTU input, etc.). The frequency of the Pulse Output is dependent on the input frequency and the user entered K Factor. Through programming, the output pulse width and state can be varied. For instructions on how to set the pulse output level, see the SETTING THE PULSE OUTPUT LEVEL section of this manual. It is recommended that twisted, shielded pair cable be used for the wiring of the pulse output. The shield should be connected to the negative (-) terminal of the terminal block for best noise immunity.

Ensure the polarity of the external device is correct or damage may occur to one or both devices.

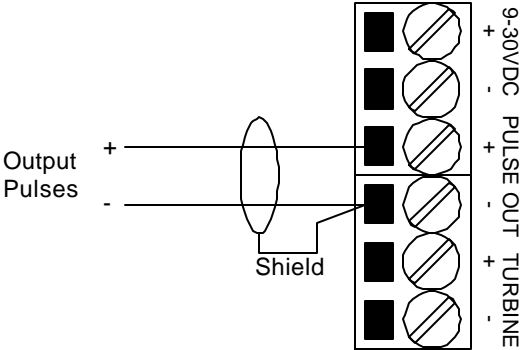

Power

IMPORTANT!

Before applying power to the SFT880 ensure the supply is set to a voltage the unit can accept, otherwise damage to the SFT880 is very likely.

Before applying power to the SFT880 for the first time, ensure any related alarm/control equipment is disabled until satisfactory system operation and performance is verified.

The SFT880 is designed to operate from 9VDC to 30VDC. To connect power to the SFT880 use terminals 1 and 2 of the terminal block (labeled 9-30VDC). For improved system noise immunity use a shielded, twisted pair with the shield connected to the negative terminal at one end only.

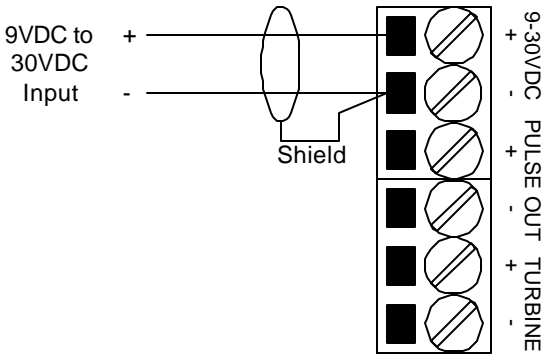

Setting the Pulse Output Level

The pulse output of the SFT880 can be set using two different methods. The output can be set to use an internal pullup resistor to the power supply input, or it can be set to an open drain output, which requires an external voltage for proper operation. **The jumper J2 is used to select which output method is used.**

With **J2 in** the internal pullup is enabled. This causes the output to have a high level of approximately the power supply input voltage minus one volt (eg. if the supply is set to 12VDC the output high level will be approximately 11V).

With **J2 out** the internal pullup is disabled. This causes the output to require an external pullup at the device reading the pulse output.

Note: For best signal results it is recommended that the internal pullup not be used.

[See the installation diagrams on the following pages for wiring configurations](#)

PULSE OUTPUT CONNECTION FOR NON-HAZARDOUS LOCATIONS

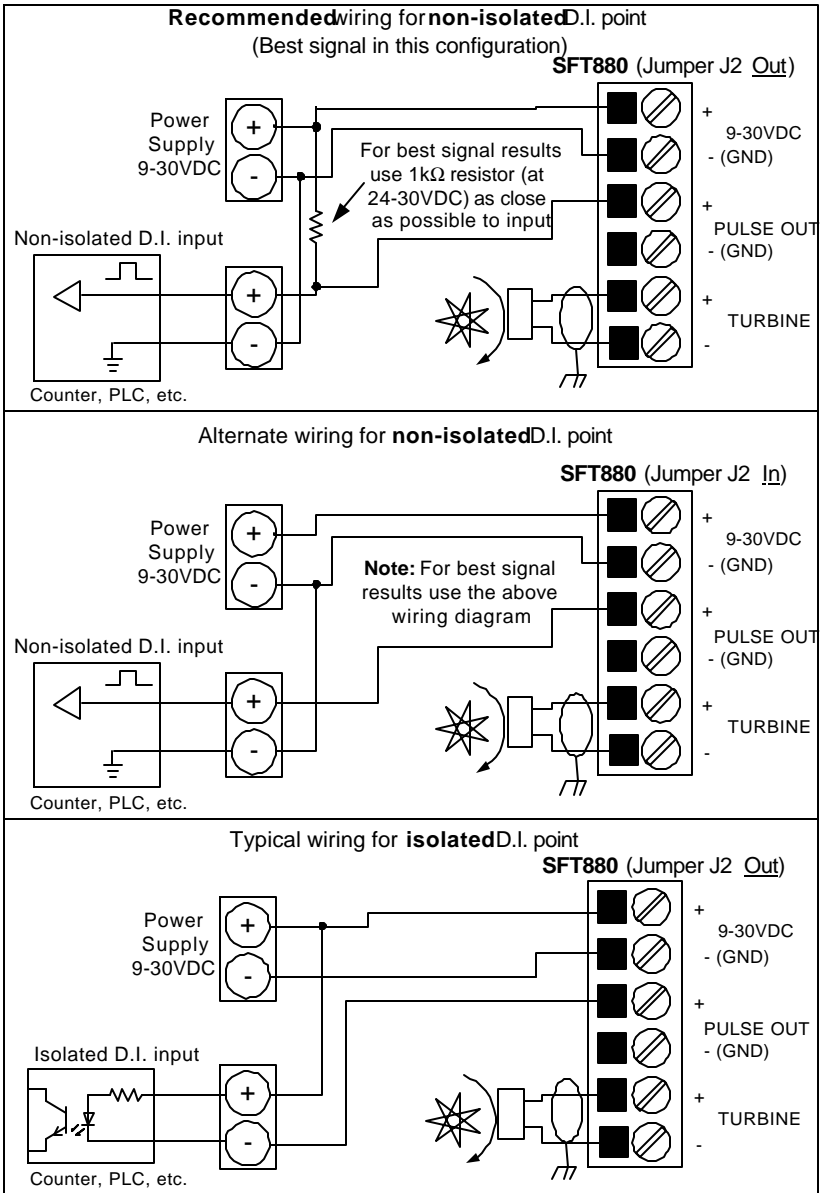

PULSE OUTPUT CONNECTION FOR HAZARDOUS LOCATIONS

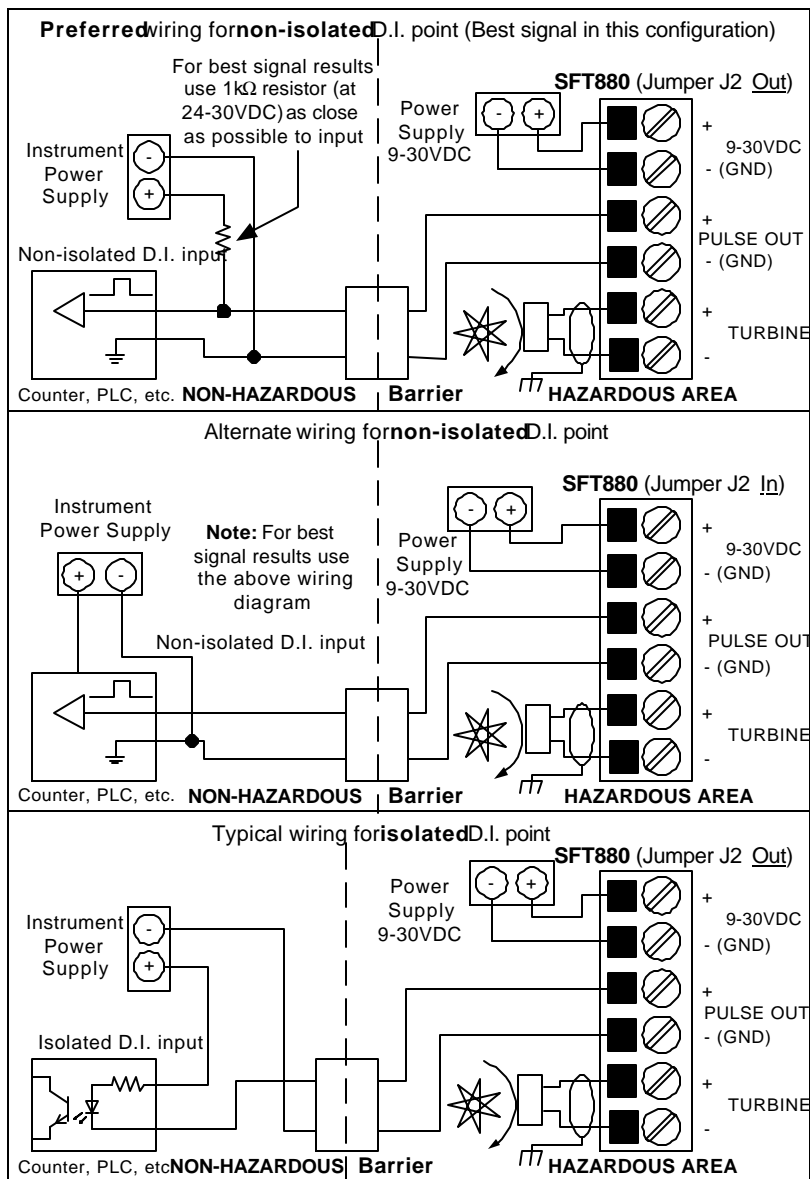

Adjusting the Gain Sensitivity

NOTE: The sensitivity is preset, at the factory, to a level which is sufficient for 95% of the applications that the SFT880 was designed for. The sensitivity should not need to be adjusted.

Other sources of poor signals should be explored before adjusting the sensitivity of the SFT880.

The SFT880 has been designed with an adjustable sensitivity. This is adjusted through the use of jumper J1 and trim pot TR1. This adjustment is provided for the user to optimize the SFT880's input circuitry for the type of input pulse.

The jumper J1 provides two general sensitivity levels:

A (HIGH, right position): This is the **default** sensitivity setting. This position is where the jumper should be for most applications. The sensitivity for position A can be adjusted using trim pot TR1. **The factory setting should be sufficient for 95% of the applications.**

B (LOW, left position): This position is to be used for very large (>1.5V) input signals. The trim pot **TR1 has no effect** on the sensitivity in this position.

The preferred method for adjusting the sensitivity is as follows:

1. Set jumper J1 to position A.
2. Reduce the flow through the turbine to the lowest possible flow rate.
3. Turn TR1 CCW all the way (about 20 revolutions). This will decrease the sensitivity to the least sensitive setting.
4. Slowly increase (turn TR1 CW) the sensitivity until the unit picks up the turbine signal solidly (the decimal place on the Numeric LED will flash consistently with the rotation of the turbine).

Operation When Installed Correctly

During normal operation the SFT880 counts the input pulses, compares that number to the K factor value, and if equal outputs a pulse (ie: if the K factor is set to 500 the output will not pulse until the SFT880 has counted 500 input pulses). For each input pulse the decimal point on the numeric LED will flash once. As the input frequency increases the brightness of the decimal point will increase, while at frequencies below 300Hz the decimal point will be dim and hard to see.

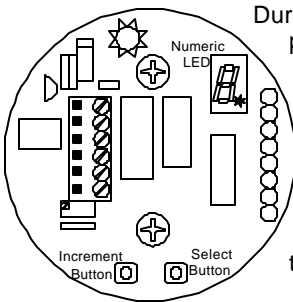

Programming

The SFT880 has been designed with three (3) programmable parameters. These are:

- K Factor:* This value determines how many input pulses are counted before the output pulses once.
- Pulse Width:* This value determines how long each output pulse is on.
- Pulse State:* This value determines the normal (off) state of the output.

Note: When in programming mode the pulse output of the SFT880 is disabled!

The two buttons at the bottom of the SFT880 are used to program in the parameters. Pressing either button during normal operation will disable the output and put the SFT880 into programming mode. See the following diagram for the location of the components needed for programming.

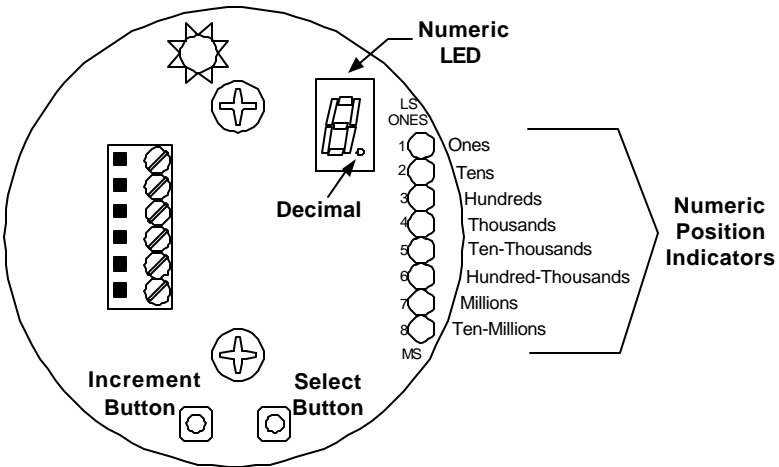

K Factor

After pressing either button in normal operating mode the SFT 880 will enter K factor programming mode. The Numeric Position Indicators will show the least significant (Ones) position, and the Numeric LED will indicate the K factor value in that position. **The default K factor value is 100.**

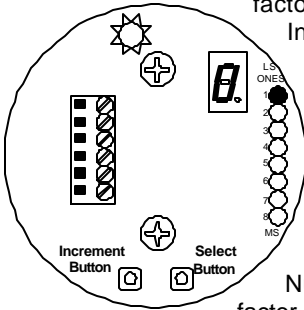

The K factor can be a maximum of 8 decimal digits (00 000 000 to 99 999 999). One of the eight Numeric Position Indicators will be on at all times when viewing or changing the K factor. The Numeric Position Indicators show where in the K factor value that the current digit is located. The buttons

act as follows:

Select: Displays the next more significant digit in the K factor (ie: pressing **select** from the tens position shows the hundreds position, pressing **select** again shows the thousands position). After the most significant (ten-millions) position is reached the Numeric Position Indicators return to the least significant (ones) position.

Increment: Increments the value of the digit being displayed. After a value of 9 the display will return to zero.

Both: Pressing **both buttons at the same time** will save the current K factor into non-volatile EEPROM memory. All eight Numeric Position Indicators will flash briefly to indicate that the memory is being updated and the SFT880 will resume normal operation.

If the SFT880 does not register a button press for a period of 90 seconds the unit will return to normal operating mode and the information in memory will not be changed.

See the **Programming Example** section for step by step instructions.

Output Pulse Width and Pulse State

Pressing both buttons simultaneously for 5 seconds or more in the K factor programming mode puts the SFT 880 in Pulse Width / Pulse State programming mode.

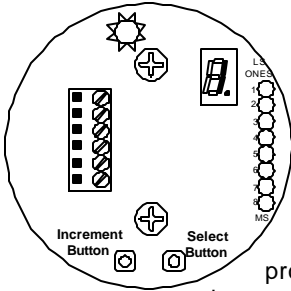

NOTE

Releasing the buttons too soon will cause the current K factor value to be saved and the unit will return to normal operating mode. Ensure the buttons are held down for 5 seconds or more to change programming modes.

Upon entering Pulse Width / Pulse State programming mode the Numeric LED decimal place will be on steady and the Numeric LED will indicate the current Pulse Width code. **The default Pulse Width is 25mS.**

In this programming mode the Select button displays and changes the Pulse State code and the Increment button displays and changes the Pulse Width code. Pressing the appropriate button once will change the display to show the appropriate code. Pressing the button in the mode it is used for will increment the code (ie. When in Pulse Width mode, pressing the Select button will cause the display to show the Pulse State code while pressing the Increment button will change the Pulse width code). The codes for the buttons are as follows:

- Select:** Displays and changes Pulse State code:
 - 8 → normally high (default)
 - 9 → normally low
- Increment:** Displays and changes Pulse Width code:
 - 0 → 0.15mS
 - 1 → 25mS (default)
 - 2 → 100mS
 - 3 → 500mS
 - 4 → 1S
- Both:** Pressing **both buttons at the same time** will save all current parameters into non-volatile EEPROM memory. All eight Numeric Position Indicators will flash briefly to indicate that the memory is being updated and the SFT880 will resume normal operation.

If the SFT880 does not register a button press for a period of 90 seconds the unit will return to normal operating mode and the information in memory will not be changed.

See the **Programming Example** section for step by step instructions.

Programming Example

- User desires:
- K factor of 648 (previous K factor is 100)
 - Output line is low when pulse is off high when pulse is on (normally low Pulse State)
 - Output Pulse Width of 100mS

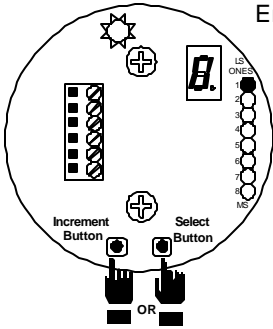

Enter Programming mode:

Press **either** button once to enter programming mode. The K factor programming mode will always start displaying the ones position of the current K factor.

Setting the K factor:

Press the **Increment** button until the desired value for the ones position is displayed (ie. 8).

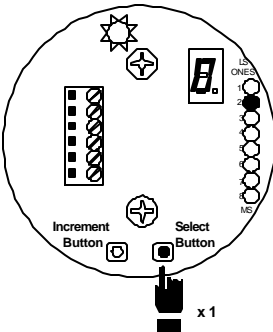
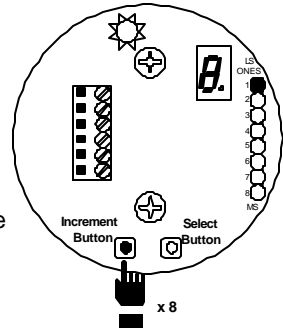

Press the **Select** button to change to the tens position.

Press the **Increment** button until the desired tens value is displayed (ie. 4).

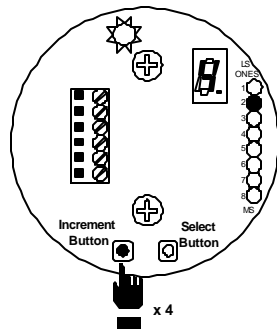

Press the **Select** button to change to the hundreds position.

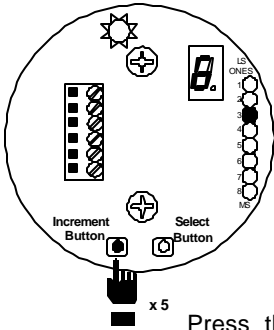
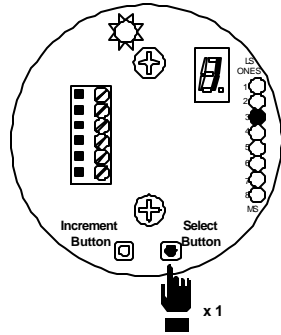

Press the **Increment** button until the desired hundreds value is displayed (ie. 6).

Press the **Select** button to cycle through the remaining numbers and verify that they are all zero. Change if needed.

Note: If we only want to change the K factor (not the Pulse Width or Pulse State) we can exit Programming mode now by pressing both buttons. This will save the new K factor and resume normal operation.

Enter Pulse Width / Pulse State Programming Mode:

From the K factor programming mode press and hold **both buttons for more than 5 seconds** to enter Pulse Width / Pulse State programming mode. The pulse width code will appear on the Numeric LED and the decimal place will turn on.

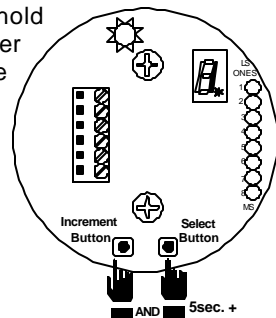

Setting the Pulse Width:

Upon entering Pulse Width / Pulse State programming mode the Pulse Width code is the first value which will appear on the Numeric LED.

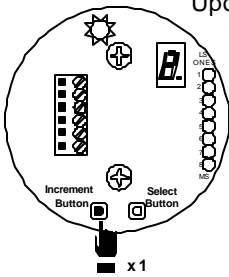

Press the **Increment** button until the desired code is showing (ie. 2).

- The codes are:
- 0 → 0.15mS
 - 1 → 25mS
 - 2 → 100mS
 - 3 → 500mS
 - 4 → 1S

Setting the Pulse State:

From the Pulse Width Mode press the **Select** button to view the current Pulse State.

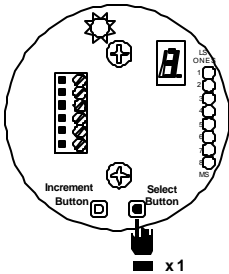
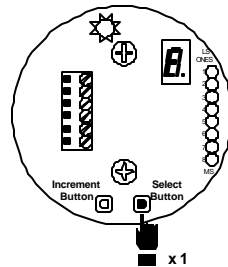

To change the Pulse State code press the **Select** button again.

The codes are:

- 8 → normally high (pulses will be low)
- 9 → normally low (pulses will be high)

To return to the current Pulse Width code, press the **Increment** button.

Pressing **both buttons for less than 5 seconds** at any time will save all parameters as they are at that time into memory. This will cause all eight Numeric position indicators to flash briefly while the memory is updated. After the memory is updated the unit will resume normal operation.

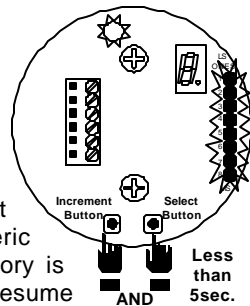

Volume Conversion Factors

Sometimes, in order to have pulses occur at the correct volume units, it is necessary to use a different K factor value than that which is supplied with the turbine in use. For this purpose the following volume conversions are provided.

| | |
|--------------------------|------------------------|
| 1 US gallon | = 0.00379 cubic meters |
| 1 US gallon | = 3.79 litres |
| 1 cubic meter | = 263.85224 US gallons |
| 1 cubic meter | = 35.31 cubic feet |
| 1 litre | = 0.26385 US gallons |
| 1 barrel = 42 US gallons | = 0.159 cubic meters |
| 1 cubic foot | = 0.00283 cubic meters |

Example:

A turbine produces 14727.27 pulses for 1 US gallon.

Desired output is in cubic meters.

1 US gallon = 0.00379 cubic meters (from above information).

$$\frac{14727.27 \text{ pulses per US gallon}}{0.00379} = 3885823$$

3885823 is the value of the converted K factor. This is the number you would enter into the SFT880.

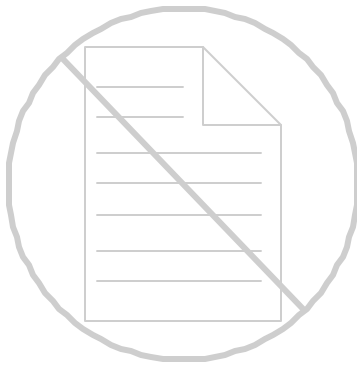

Troubleshooting

| Problem | Possible Solution |
|--|---|
| There is no output signal (Numeric LED decimal place not on) | <ol style="list-style-type: none">1. Check that the pulse output is wired properly (see INSTALLATION section of this manual).2. Check that the power supply voltage is between 9VDC and 30VDC.3. Check the MAIN POWER FUSE.4. Check that the main power polarity is correct.5. Check that the power input is connected to the correct terminals.6. Ensure there are no metal filings on or under the card.7. Check for loose connections.8. Check that the turbine input is properly connected.9. Check that the turbine meter is turning freely and the pickup coil is adjusted for the correct depth or distance from the blades.10. Turbine input sensitivity may need to be increased (see the ADJUSTING GAIN SENSITIVITY section of this manual). |
| There is no output signal (Numeric LED decimal place on or flashing) | <ol style="list-style-type: none">1. Check that the pulse output is wired properly (see INSTALLATION section of this manual). Pay particular attention to the pullup resistor on the output.2. Check that the turbine input is properly connected.3. Check that the Pulse width is not larger than the time between pulses (see the PROGRAMMING section of this manual to read K factor and Pulse Width). |
| Output Pulses are erratic and higher than expected | <ol style="list-style-type: none">1. Pulse State may be incorrect for the counter being used (see the PROGRAMMING section of this manual to invert the output Pulse State).2. The turbine input sensitivity may be too high (see the ADJUSTING GAIN SENSITIVITY section of this manual to decrease the sensitivity). |
| The unit works but the flow totalizer still counts when the meter is stopped | <ol style="list-style-type: none">1. Check that the shield is installed properly2. The turbine input cable may be too long. Locate the SFT880 to allow for the shortest possible cable.3. The turbine input cable may have a high capacitance per foot. Place a 1kΩ ½ Watt resistor across the TURBINE terminals on the SFT880.4. The sensitivity may be too high. Refer to the ADJUSTING GAIN SENSITIVITY section of this manual. |

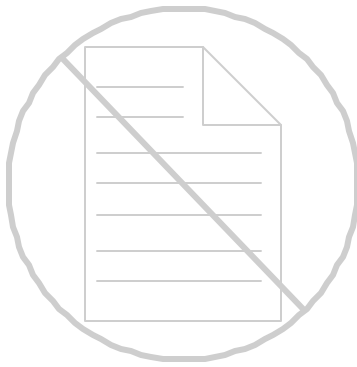

Specifications

SFT880 PULSE OUTPUT FLOW CONVERTER

- Power: - 9VDC to 30VDC
- Current Consumption: - 10mA (no LEDs on)
- Power Fuse: - 1/8 A Pico Fuse
- Ambient Temperature: - Storage: -60°C to +85°C (-76°F to +185°F)
- Operating: -40°C to +70°C (-40°F to +149°F)
- Humidity: - 0% to 95% non-condensing without gasket
- Inputs: - Accepts turbine or digital inputs
- Minimum: - 15mVRMS @ 0.1Hz
- 25mVRMS @ 4kHz
- Maximum: - 30VRMS
- Frequency: - 0Hz to 4kHz
- Outputs: - Power input voltage less 1V using internal pullup (J2in).
- Open drain for external pullup (J2 out).
- Output frequency equal to input frequency divided by K factor.
- Output pulse width and state set through user programming.
- 1500 feet maximum distance with an 18 awg shielded twisted pair cable.
- Program Memory: - Non-Volatile EEPROM.
- Enclosure: - CSA approved CLASS I, DIVISION II, GROUPS B, C, & D
- NEMA 3 & 4
- Explosion proof
- Requires conduit to safe area
- Weight: - 1.4kg (3.0lbs)

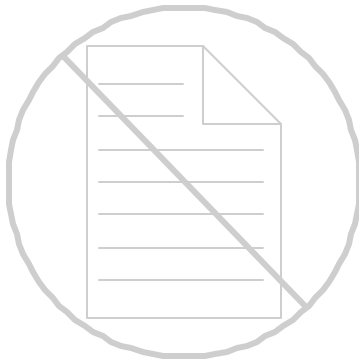

Notes
