



Head Office
4130 – 93 Street
Edmonton, AB, Canada T6E 5P5
P (780) 462-4085
F (780) 450-8369

Saskatchewan Branch
Box 460, 103 Cenaiko Street
Lampman, SK, Canada S0C 1N0
P (306) 487-2883
F (306) 487-2889

 Manufactured in Canada

© 2002 Titan Logix Corp.

Toll Free 1-877-462-4085

Web Site www.titanlogix.com

E-Mail sales@titanlogix.com

1000172MUI04
Rev. 05

SFT 881

Operation Manual



At Titan Logix Corp., we endeavor to design equipment that is simple to use and reliable in its operation, with the aim of satisfying our customers needs.

Titan Logix Corp. fields of expertise include:

- Level and Flow Measurement
- Transport Instruments
- Burner and Combustion
- Communication and Control System Integration and
- Drilling Fluid Monitoring

We have been designing and manufacturing electronic equipment since 1980. Titan Logix Corp. unites four companies, each a leader in different segments of the oil and gas industry:

- Titan Technologies
- Nagy Burner Control (NBC)
- Sherrex Systems
- Alberta Industrial Technologies (AIT)

Titan Logix Corp. sells and markets through subsidiaries, distributors, and representatives. Through continuous improvement we are striving to provide our customers with first rate sales information, engineering assistance, and after sales support.

Titan Logix Corp.

SFT881

WARRANTY STATEMENT

WARRANTY: Titan Logix Corp. warrants all equipment of its own manufacture to be free of defects in material and workmanship for a period of twelve (12) months from date of shipment. Titan Logix Corp.'s sole obligation hereunder shall be expressly limited to repair or exchange free of charge, F.O.B. Edmonton, Alberta, Canada, of such defective equipment (alternatively, Titan Logix Corp. will, at its option, refund the purchase price). Titan Logix Corp.'s obligation under this warranty is limited to the above and does not apply to exchange or repairs, which are required as a result of improper installation, misuse, maladjustment, abnormal operating conditions, or lack of routine maintenance. Nor does the warranty include the furnishing of service for maintenance or problems arising from the foregoing causes. No claims for labour, installation, removal, transportation, or other expenses will be recognized. Notwithstanding any stipulation of the purchaser to the contrary, all other obligations, representations, warranties and conditions, express or implied, statutory or otherwise, including any implied warranties or conditions of merchantability, quality or fitness are hereby excluded and, Titan Logix Corp. shall not be liable for any loss, cost or damages, of any kind whatsoever, whether consequential, indirect, special or otherwise, arising out of or in connection with the equipment or any defect therein, even if caused by the negligence of, Titan Logix Corp., its employees or agents. The provisions hereof relating to the warranty and limitations hereon and limitation of liability shall continue to be enforceable between the parties notwithstanding termination of the within agreement for any reason including fundamental breach. Equipment not of, Titan Logix Corp. manufacture will carry the vendor's or manufacturers standard warranty.

Table of Contents

Introduction	6
About This Manual.....	6
About the SFT881	7
Main Features.....	7
Installation	8
Environmental.....	8
Outline	9
Mounting.....	9
Interconnection	10
Turbine Input	11
Pulse Output.....	12
Power	13
Setting the Pulse Output Level	14
Adjusting the Gain Sensitivity	14
Operation When Installed Correctly.....	14
Programming	15
K Factor.....	16
Output Pulse Width and Pulse State	17
Programming Example	18
Volume Conversion Factors	19
Troubleshooting	20
Specifications	21

Introduction

About This Manual

This instruction manual provides information specific to the Titan Logix Corp. SFT881. Other peripheral equipment should be supplied with its own instruction manual and that manual should be referred to for proper operation of the peripheral equipment.

It is essential that this manual be read and understood for proper installation and operation of your SFT881.

This manual includes:

<i>INTRODUCTION:</i>	Briefly describes the key features of the SFT881.
<i>INSTALLATION:</i>	Detailed description of mounting and wiring of external equipment. Also has description of normal operation.
<i>PROGRAMMING:</i>	Describes the method for programming the K factor, pulse width, and output pulse state.
<i>TROUBLESHOOTING:</i>	Describes several quick problem-solving techniques.
<i>SPECIFICATIONS:</i>	Describes the physical and operational characteristics.

About the SFT881

The SFT881 is an inexpensive interface between the low-level pulses produced by a turbine and the higher level pulses required by a standard digital input. This allows the SFT881 to be connected to many different totalization devices from dedicated flow totalizers up to standard RTU and PLC inputs. The SFT 881 is designed with a user programmable K factor to allow the input signal to be divided into more useable volume measures, this allows for standard digital accumulators to act as more easily as a flow totalizer.

The wide range of input power, low current consumption, K factor, and explosion proof enclosure combine to make the SFT881 a highly versatile and inexpensive solution to turbine interface problems.

Please refer to the INSTALLATION section of this manual for directions on how to connect and set up The SFT881.

Main Features

- Enclosure: CSA approved Class I, DIVISION I, GROUPS B, C, & D, NEMA 3 & 4.
- Input/Output: Turbine input from 0Hz to 3kHz at 20mVpp(7mVrms) to 30Vpp(10Vrms). Adjustable pulse input sensitivity for use with different type of turbine inputs. Isolated pulse output capable of switching 100mA at 300V. Output frequency will depend on input frequency and K factor.
- Reliability: Built using industrial specified components to ensure long life and reliability even in harsh conditions.
- Programming: The user can program The SFT881. The programmable features are K factor, (from 1 to 9,999,999), output pulse width (0.15mS, 25mS, 100mS, 500mS, 1S), and output pulse state (normally open or normally closed). With the pulse width set at 0 the SFT881 will act as a rate alarm.

Installation

Installation should only be performed by qualified personnel, and in accordance with local governing regulations.

Environmental

Choose a mounting location suited to the SFT881 enclosure.

The ideal SFT881 mounting location is where the:

1. Turbine pickup is as close as possible.
2. Mounting surface has minimal vibration.
3. Ambient temperature is always within -40°C to $+65^{\circ}\text{C}$ (-40°F to $+149^{\circ}\text{F}$).
4. Cable lengths are minimal.
5. Terminal labeling is visible.

Avoid mounting locations where the SFT881 is:

- Vibrating.
- Close to high voltage/current runs, contactors, SCR control devices, or frequency inverters.

Outline

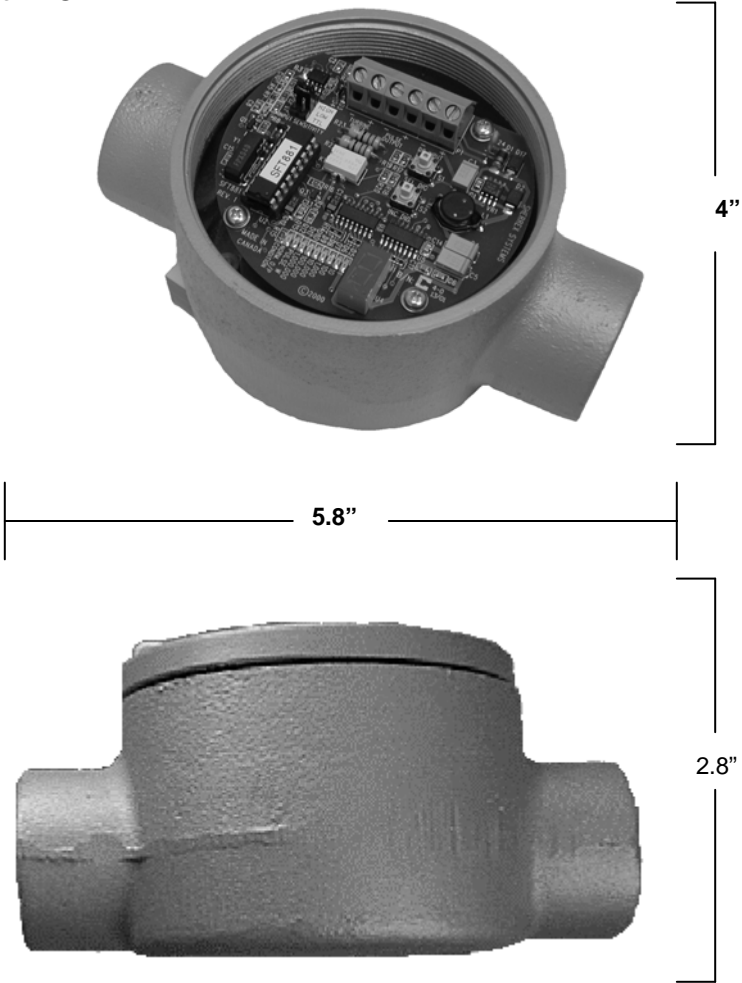

Mounting

The SFT881 has been designed to mount directly onto a **standard 1" threaded rigid conduit or equivalent reducing fitting.**

Interconnection

Perform all wiring in accordance with local governing regulations.

Please refer to the diagram below for the location of the configuration jumpers and the I/O terminals on the SFT881.

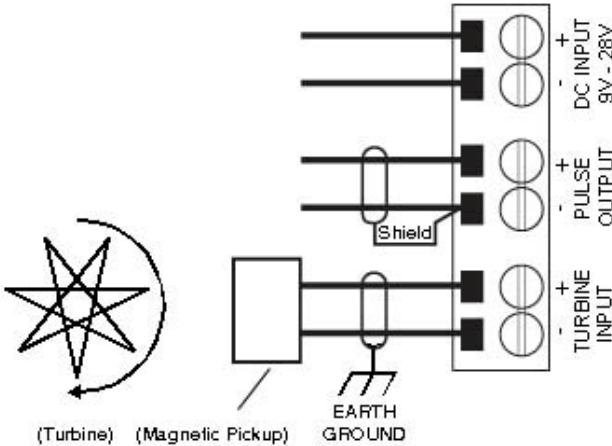
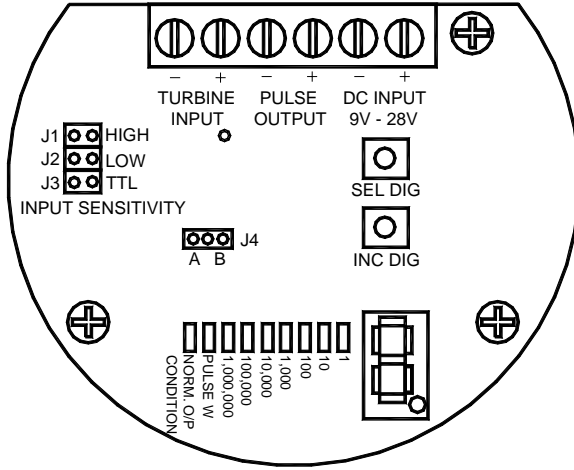

Turbine Input

The turbine input is a **non-polarized input**. To connect the magnetic pickup to the SFT881, bring the wires to terminals 1 and 2 of the terminal block (labeled TURBINE).

NOTE: To prevent improper operation and false input readings, the SFT881 should be mounted as close as possible to the turbine's magnetic pickup.

If the SFT881 cannot be mounted close to the pickup, use shielded cable and connect the shield to Earth Ground at one end only.

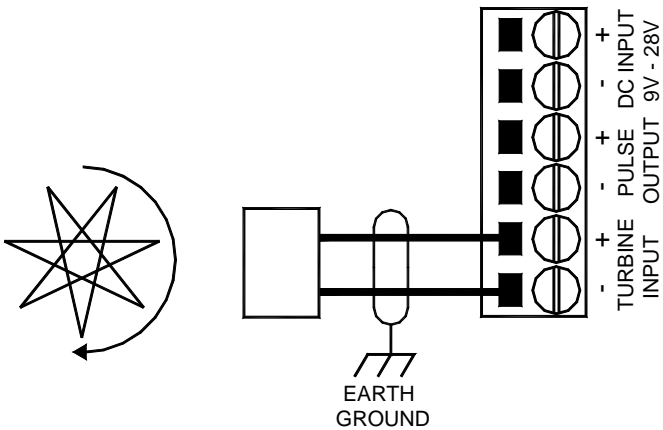

Pulse Output

The SFT881 has photovoltaic relay output for connection to external monitoring equipment (eg. flow totalizer, PLC input, RTU input, etc.). This relay is rated for 50mA maximum current draw with a maximum voltage of 300V across the terminal blocks. The frequency of the Pulse Output is dependent on the input frequency and the user entered K Factor. Through programming, the output pulse width and state can be varied. For instructions on how to set the pulse output level, see the SETTING THE PULSE OUTPUT LEVEL section of this manual. It is recommended that twisted, shielded pair cable be used for the wiring of the pulse output. The shield should be connected to the negative (-) terminal of the terminal block for best noise immunity.

Ensure the polarity of the external device is correct or damage may occur to one or both devices.

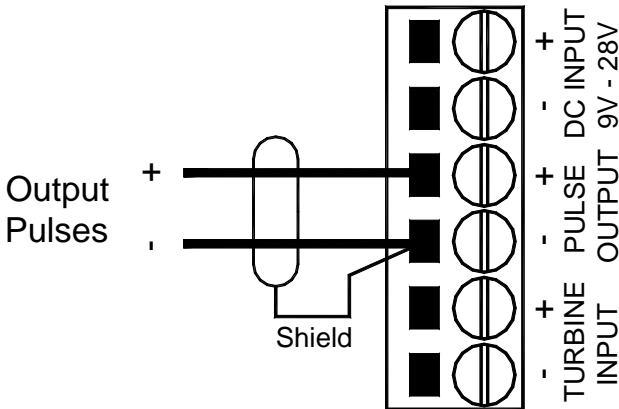

Power

IMPORTANT!

Before applying power to the SFT881 ensure the supply is set to a voltage the unit can accept, otherwise damage to the SFT881 is very likely.

Before applying power to the SFT881 for the first time, ensure any related alarm/control equipment is disabled until satisfactory system operation and performance is verified.

The SFT881 is designed to operate from 9VDC to 28VDC. To connect power to the SFT881 use terminals 1 and 2 of the terminal block (labeled 9-28VDC).

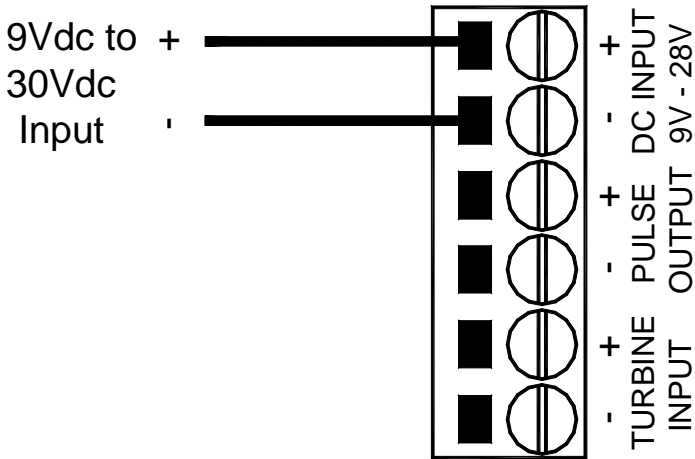

Adjusting the Gain Sensitivity

The INPUT SENSITIVITY JUMPERS provide three general sensitivity levels:

HIGH, Top position: The sensitivity for position A is good for a 20mVpp signal.

LOW, Middle position: This is the **default** sensitivity setting. This position is where the jumper should be for most applications. This position is to be used for turbine output signals greater than 35mVpp.

TTL, Bottom position: With the jumper in this position the SFT881 will accept TTL/CMOS level pulses. Only turbines that have gone through a signal conditioner should use this jumper position.

Operation When Installed Correctly

During normal operation the SFT881 counts the input pulses, compares that number to the K factor value, and if equal outputs a pulse (ie: if the K factor is set to 500 the output will not pulse until the SFT881 has counted 500 input pulses). For each input pulse the decimal point on the numeric LED will flash once. As the input frequency increases the brightness of the decimal point will increase, while at frequencies below 300Hz the decimal point will be dim and hard to see.

Programming

The SFT881 has been designed with three (3) programmable parameters. These are:

K Factor: This value determines how many input pulses are counted before the output pulses once.

Pulse Width: This value determines how long each output pulse is on.

Pulse State: This value determines the normal (off) state of the output.

To use this product as a basic pre amp, simply put J4 in the "A" position. This will bypass all programmable parameters in the processor. To use the programmable parameters put J4 in the "B" position.

Note: When in programming mode the pulse output of the SFT881 is disabled!

The two buttons labeled "SEL DIG" (SELECT DIGIT) and "INC DIG" (INCREMENT DIGIT) are used to program in the parameters. Pressing either button during normal operation will disable the output and put the SFT881 into programming mode. See the following diagram for the location of the components needed for programming.

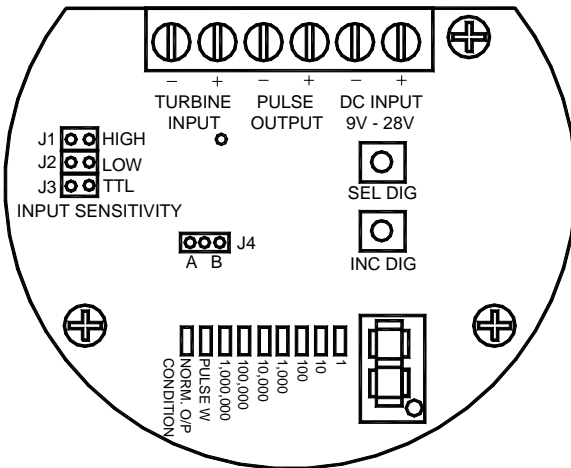

K Factor

After pressing either button in normal operating mode the SFT 881 will enter K factor programming mode. The Numeric Position Indicators will show the least significant (Ones) position, and the Numeric LED will indicate the K factor value in that position. **The default K factor value is 1.**

The K factor can be a maximum of 7 decimal digits (0 000 001 to 9 999 999). One of the seven Numeric Position Indicators will be on at all times when viewing or changing the K factor. The Numeric Position Indicators show where in the K factor value that the current digit is located.

Pressing the SEL DIG button displays the next more significant digit in the K factor (ie: pressing **select** from the tens position shows the hundreds position, pressing **select** again shows the thousands position). After the most significant (millions) position is reached the select button will then display the pulse width value and the normal output state before the Numeric Position Indicators return to the least significant (ones) position.

Pressing the INC DIG button increments the value of the digit being displayed. After a value of 9 the display will return to zero.

Once the desired value is obtained on the display the value is ready to be saved into nonvolatile memory. This is accomplished by pressing the SEL DIG and INC DIG simultaneously for 5 seconds. When the display starts to count down from three the buttons may be released. The values are now saved and the SFT881 will resume normal operation.

If the SFT881 does not register a button press for a period of 90 seconds the unit will return to normal operating mode and the information in memory will not be changed.

See the **Programming Example** section for step by step instructions.

Output Pulse Width

Press the Select Digit button till the Pulse Width LED is displayed. This will cause the 7-segment display to indicate the current value stored as a pulse width. Below is what each digit represents for each pulse width. **The default Pulse Width is 0.15mS.**

- 0 → Rate Alarm (see the end of this section)
- 1 → 0.15mS (default)
- 2 → 25mS
- 3 → 100mS
- 4 → 500mS
- 5 → 1S

The Increment button increments the Pulse Width code. Once the desired value is obtained on the display the value is ready to be saved into nonvolatile memory. This is accomplished by pressing the SEL DIG and INC DIG simultaneously for 5 seconds. When the display starts to count down from three the buttons may be released. The values are now saved and the SFT881 will resume normal operation.

Rate Alarm- If this value is set to 0 the SFT881 acts as a Rate Alarm. The value loaded for a K-Factor now is used for a maximum Rate and the output will be continuously energized or de-energized. If the K factor is set at 1000, the Output Pulse Width is set to 0, and the Normal Output condition is set to 1 then the output relay contact will remain closed until the input pulses exceed 1000 pulses per second. At this frequency the contact will then open and stay open till the frequency drops below 1000.

Normal Output Condition

Press the Select Digit button till the Norm O/P condition LED is displayed. This will cause the 7-segment display to indicate the current value stored as a normal output state of the relay. Below is what each digit represents for each output state. **The default is 1 or normally closed contacts.**

- 1 → normally closed (Relay energized, default)
- 0 → normally open

Once the desired value is obtained on the display the value is ready to be saved into nonvolatile memory. This is accomplished by pressing the SEL DIG and INC DIG simultaneously for 5 seconds. When the display starts to count down from three the buttons may be released. The values are now saved and the SFT881 will resume normal operation.

If the SFT881 does not register a button press for a period of 90 seconds the unit will return to normal operating mode and the information in memory will not be changed.

See the **Programming Example** section for step by step instructions.

Programming Example

User desires:

- K factor of 648 (previous K factor is 1)
- Output line is low when pulse is off and is high when pulse is on (normally low Pulse State)
- Output Pulse Width of 100mS

Enter Programming mode:

Press **either** button once to enter programming mode. The K factor-programming mode will always start displaying the ones position of the current K factor.

Setting the K factor:

Press the **Increment** button until the desired value for the ones position is displayed (ie. 8).

Press the **Select** button to change to the tens position.

Press the **Increment** button until the desired tens value is displayed (ie. 4).

Press the **Select** button to change to the hundreds position.

Press the **Increment** button until the desired hundreds value is displayed (ie. 6).

Press the Select button to cycle through the remaining numbers and verify that they are all zero. Change if needed.

Note: If we only want to change the K factor (not the Pulse Width or Pulse State) we can exit Programming mode now by pressing both buttons. This will save the new K factor and resume normal operation.

Enter Pulse Width / Pulse State Programming Mode:

Press Select until PULSE W LED is lit up

Setting the Pulse Width:

Press the **Increment** button until the desired code is showing (ie. 3).

The codes are: 0 → rate alarm
1 → 0.15mS
2 → 25mS
3 → 100mS
4 → 500mS
5 → 1S

Setting the Output Condition:

Press Select until NORM O/P condition LED is lit.

To change the output condition code press the **Increment** button again (ie. 1)

The codes are:

0 → normally open (pulses will be low)
1 → normally closed (pulses will be high)

Hold both buttons for 5 seconds. When display starts to count down from 3 the buttons may be released.

The changes are then stored.

Volume Conversion Factors

Sometimes, in order to have pulses occur at the correct volume units, it is necessary to use a different K factor value than that which is supplied with the turbine in use. For this purpose the following volume conversions are provided.

1 US gallon	= 0.0037854 cubic meters
1 US gallon	= 3.78541 litres
1 cubic meter	= 264.17205 US gallons
1 cubic meter	= 35.31467 cubic feet
1 litre	= 0.26417 US gallons
1 barrel = 42 US gallons	= 0.15899 cubic meters
1 cubic foot	= 0.028317 cubic meters

Example:

A turbine produces 14727.27 pulses for 1 US gallon.

Desired output is in cubic meters.

1 US gallon = 0.0037854 cubic meters (from above information).

$$\frac{14727.27 \text{ pulses per US gallon}}{0.0037854} = 3890545$$

3890545 is the value of the converted K factor. This is the number you would enter into the SFT881.

Troubleshooting

Problem

Possible Solution

There is no output signal
(Numeric LED decimal place not on)

1. Check that the pulse output is wired properly (see INSTALLATION section of this manual).
2. Check that the power supply voltage is between 9VDC and 28VDC.
3. Check the MAIN POWER FUSE.
4. Check that the main power polarity is correct.
5. Check that the power input is connected to the correct terminals.
6. Ensure there are no metal filings on or under the card.
7. Check for loose connections.
8. Check that the turbine input is properly connected.
9. Check that the turbine meter is turning freely and the pickup coil is adjusted for the correct depth or distance from the blades.
10. Turbine input sensitivity may need to be adjusted.

There is no output signal
(Numeric LED decimal place on or flashing)

1. Check that the pulse output is wired properly (see INSTALLATION section of this manual).
2. Check that the Pulse width is not larger than the time between pulses (see the PROGRAMMING section of this manual to read K factor and Pulse Width).

Output Pulses are erratic and higher than expected

1. Pulse State may be incorrect for the counter being used (see the PROGRAMMING section of this manual to invert the output Pulse State).
2. The turbine-input sensitivity may be too high.

The unit works but the flow totalizer still counts when the meter is stopped

1. Check that the shield is installed properly
2. The turbine input cable may be too long. Relocate the SFT881 to allow for the shortest possible cable.
3. The turbine input cable may have a high capacitance per foot. Place a 1kΩ ½Watt resistor across the TURBINE terminals on the SFT881.
4. The sensitivity may be too high.

Specifications

SFT881 PULSE OUTPUT FLOW CONVERTER

Power:	- 9VDC to 28VDC
Current Consumption:	- 50mA max
Power Fuse:	- 100mA resetable PTC
Ambient Temperature:	- Storage: -60°C to +85°C (-76°F to +185°F) - Operating: -40°C to +65°C (-40°F to +149°F)
Humidity:	- 0%to 95% non-condensing without gasket
Inputs:	- Accepts turbine or digital inputs - Minimum: - 8mVRMS @ 0.1Hz - Maximum: - 30VRMS - Frequency: - 0Hz to 3kHz
Outputs:	- Isolated Contact (N.O. when power removed from system). - 50mA 30V contact rating - Output frequency equal to input frequency divided by K factor. - Output pulse width and state set through user programming.
Program Memory:	- Non-Volatile EEPROM.
Enclosure:	- CSA approved CLASS I, DIVISION I, GROUPS B, C, & D - NEMA 3 & 4 - Explosion proof - Requires conduit to safe area
Weight:	- 1.4kg (3.0lbs)

Notes

Notes
