

# VISI 1310

## Installation Manual



**Head Office**  
4130 – 93 Street  
Edmonton, AB T6E 5P5

**Saskatchewan Branch**  
Box 460, 103 Cenaiko Street  
Lampman, SK S0C 1N0



Manufactured in Canada

**Toll Free** 1-877-462-4085

**Web Site** [www.titanlogix.com](http://www.titanlogix.com)

**E-Mail** [sales@titanlogix.com](mailto:sales@titanlogix.com)

## **VISI Manual**

### **WARRANTY STATEMENT**

**WARRANTY:** Titan Logix Corp. warrants all equipment of its own manufacture to be free of defects in material and workmanship for a period of twelve (12) months from date of shipment. Titan Logix Corp.'s sole obligation hereunder shall be expressly limited to repair or exchange free of charge, F.O.B. Edmonton, Alberta, Canada, of such defective equipment (alternatively, Titan Logix Corp. will, at its option, refund the purchase price). Titan Logix Corp.'s obligation under this warranty is limited to the above and does not apply to exchange or repairs, which are required as a result of improper installation, misuse, maladjustment, abnormal operating conditions, or lack of routine maintenance. Nor does the warranty include the furnishing of service for maintenance or problems arising from the foregoing causes. No claims for labour, installation, removal, transportation, or other expenses will be recognized. Notwithstanding any stipulation of the purchaser to the contrary, all other obligations, representations, warranties and conditions, express or implied, statutory or otherwise, including any implied warranties or conditions of merchantability, quality or fitness are hereby excluded and, Titan Logix Corp. shall not be liable for any loss, cost or damages, of any kind whatsoever, whether consequential, indirect, special or otherwise, arising out of or in connection with the equipment or any defect therein, even if caused by the negligence of, Titan Logix Corp., its employees or agents. The provisions hereof relating to the warranty and limitations hereon and limitation of liability shall continue to be enforceable between the parties notwithstanding termination of the within agreement for any reason including fundamental breach. Equipment not of, Titan Logix Corp. manufacture will carry the vendor's or manufacturer's standard warranty.

**©2002 Titan Logix Corp.**

## VISI 1310 INSTALLATION GUIDE

**CAUTION:** Working with any toxic or flammable substance is very dangerous. Be extremely careful when drilling the hole in the top of the tank.

Proper installation is necessary to ensure trouble free operation of this gauge. Please follow the directions closely and be sure to **carefully seal the system AND INSTALL THE SUPPLIED DESICCANT IN THE BOTTOM OF THE CLEAR LEXAN INDICATOR TUBE BEFORE INSTALLING THE RED INDICATOR INTO THE TUBE (see SECTION 4 for additional info on preventing moisture from forming in the closed tube system)**

### Tools Required

- Pneumatic drill, 1 1/16" bit, pilot bits, and cutting oil
- Files (half round or round and flat)
- Two 1/2" and two 7/16" wrenches
- Hacksaw
- Flat blade screw driver
- Vise grips
- Side cutters
- Gauging tape

### SECTION 1

#### Exterior Gauge Installation:

##### COMPLETE GAUGE ONLY

- Assemble board sections, bolt magnetic or weld brackets on the Gauge Board. Loosely clamp the Lexan tube to the Gauge Board via the hose clamps. The Lexan tube will be fastened later.
- Mount board on the side of the tank (close to the thief hatch as the interior assembly is inserted through the thief hatch). If magnetic brackets are being used, be sure all of the magnets are contacting the tank.

##### HOT TAPPING

- Use extreme caution and plenty of cutting oil to drill a 1 1/16" hole in the top of the tank. Select a spot at least 12" from the tank wall and away from the fluid inlet. File the edge of the hole smooth.

##### INSTALLING ANCHOR AND FLOAT-FREE ANCHOR

- Install anchor plate to anchor fitting on the end of the 3/4" PVC tube. Slide float to base of tube.

- Gently lower the anchor plate through thief hatch to bottom of tank, then feed the tube through the previously drilled hole or reducer adapter. Pull up on the tube to center the anchor plate below the hole.
- If using S/S tube, place the spring and washer on the tube before the float.

#### INSTALLING ANCHOR AND FLOAT-FIXED ANCHOR

- Using a plum line weld brackets to bottom of tank directly below the 1" coupler or drilled hole in the top of the tank. Slide float to base of tube. Bolt anchor fitting on the end of  $\frac{3}{4}$ " PVC tube to the brackets. Feed the other end of the tube through the hole in the top of the tank.
- If using S/S tube, place spring and washer before float.

#### CLAMPING BLOCK INSTALLATION

- Slide the O-ring over tube down to tank roof. Slide on large flat washer and spring. Loosen bolts on clamping block and slide over pipe.
- While maintaining tension on the interior tube, compress the spring to half of its relaxed height with the clamping block and tighten the bolts.
- Cut tube approximately 2" above clamping block and smooth edges with file (note: keep the cut off tube – it can be used as a spacer between the cable guide and elbows.)
- If using compression fittings, see detail #2

## SECTION 2

### **Attaching Cable Guide Assembly**

#### CABLE GUIDE ALIGNMENT

- Screw one of the cable guide elbows into the  $\frac{3}{4}$ " reducer and place into 1" coupling on the clear outside tube. Place the other elbow into coupling on top of the interior tube.
- (If necessary) Cut the leftover interior tube to the distance required between the two elbows. Install the tube between the elbows.
- Level the cable guide assembly by adjusting the height of the exterior tube. Remove the cable assembly from the exterior and interior tubes and set aside.

#### INSTALLING CABLE

- Lower cable follower into interior tube until follower enters the magnetic field of the float. (NOTE: do not kink cable) Feed the other end of the cable through the cable guide assembly.
- Attach cable guide assembly to interior tube. Leave the other end to hang next to the exterior tube.

## SECTION 3

### Calibrating Gauge

- Slide crimping sleeve onto end of cable; loop the cable through the eyehook in the top of indicator and back through crimping sleeve.
- Hang the indicator down the OUTSIDE of the exterior tube and adjust the length of cable to the correct level on the calibrated board (as measured with the gauging tape). Be sure the cable guide assembly is level. Pull down gently on the cable to be sure the follower is in the float's magnetic field.
- Crimp sleeve and cut off excess cable.
  - **Pour the desiccant into the Lexan tube before inserting the indicator.**
- Lower indicator down the exterior tube. Reattach the cable guide assembly to the top of the tube. If necessary, the exterior tube can be adjusted slightly to align the indicator.
- Tighten the hose clamps to hold the exterior tube in place.

**Seal all the couplings in the cable guide assembly with silicone sealant. This is necessary to prevent moisture from entering the tubes that will affect the performance of the gauge.**

## SECTION 4

### Preventing Moisture from Forming in the Closed System

The 1310 gauge has been designed to ensure years of trouble free operation. The following outlines some recommended maintenance procedures and basic service work. All of the tasks outlined here can be done without taking the tank out of service. With the exception of replacing the O-ring, none of the work done here involves opening the tank.

1. Removing condensation from the PVC or S.S. (inside) and Lexan (outside) Tubes.
2. **WARNING: If your indicator or follower has frozen inside to the tube, follow the instructions below to correct the problem. DO NOT STEAM the inside of the tubes to free the indicator or internal follower.**

If moisture is allowed to build up inside the tubes, it is possible that the indicator or follower will freeze to the inside wall of the tube. This will cause the magnetic float to break away from the follower inside the tank. In this case, the indicator will drop down to the bottom of the tube, or not move at all.

A small amount of the blue silica desiccant is placed in the bottom of the clear tube. This will absorb a small amount of moisture that may be present in the system when the gauge is installed. It also serves as a telltale. If it turns pink or white, the desiccant is saturated and should be changed.

Remove the end cap from the bottom of the clear tube and shake the desiccant out. Remove the cable guide from the top of the vessel and place aside. Pull the indicator and cable assembly out of the tube and place aside. Using a small rag wrapped around the end of a fish tape and dipped in a small amount of de-icer (eg. Methanol). Swab both tubes to remove any unwanted moisture. To finish, use clean dry rags to assure that both tubes are dry and clean. Glue the end cap back on the clear tube with silicone. Pour about 4" of fresh desiccant down the clear tube. Gently lower the indicator and cable assembly down the assembly down the tubes and return the cable guide assembly back to its original position. Seal joints with silicone. **Be sure that all of the other connections in the systems are sealed.**

### **3. Changing the Clamping Block Assembly and O-Ring**

Remove the cable guide and set aside. Gently remove the cable and follower from the inside of the tube. Do not kink or tangle the cable. Loosen the bolts on the clamping block and remove the clamping block, spring, washer and o-ring. Be sure to hold on to the PVC tube.

Assembly is reverse of the above. Slide O-ring over tube down to tank roof. Slide on large flat washer and spring. Loosen bolts on clamping block and slide over tube. While maintaining tension on the interior tube, compress the spring to half of its relaxed height with the clamping bolt and tighten the bolts.

### **4. Renewing the Indicator**

Pull the cable guide away from the top of the outside tube. Pull the indicator out of the tube and cut the cable directly above the indicator. Recalibrate the gauge with the new indicator.

### **5. Renewing the Cable and Follower**

To renew the cable and follower, remove the cable guide and set aside. If necessary, cut the old cable and remove it along with the follower and indicator. If the indicator is to be reused, cut off the old cable at eyehook. Gently lower, the new follower down the inside tube until it enters the magnetic force field. (Note: do not kink the cable). Pull it back up and allow the follower to drop a couple of feet to ensure that the old follower has not been left in the force field.

Feed the other end of the cable through the cable guide. It may be necessary to dismantle the cable guide and feed the cable through each piece. Do not twist the cable when the cable guide is screwed back together.

Attach cable guide assembly to interior tube. Leave the other end to hang next to the exterior tube. Recalibrate the gauge.

## **6. Recalibrating the Gauge**

Slide crimping sleeve onto end of cable; loop the cable through eyehook in the top of indicator and back through crimping sleeve. Hang the indicator down the outside of the exterior tube and adjust the length of the cable to the correct level on the calibrated board (as measured with the gauging tape). Be sure the cable guide assembly is level. Pull down gently on the cable to ensure the follower is in the float's magnetic field.

Crimp sleeve and cut off excess cable. Lower indicator down the exterior tube. Reattach the cable guide assembly to top of the tube. If necessary, the clamps holding the exterior tube can be loosened to move the tube to align the indicator.

**Seal all couplings in the cable guide assembly with silicone sealant.**

Part #	Description	16 FT.		20 FT.		24 FT.	
		TYPE A	TYPE C	A	C	A	C
10	Sign Board	16'	16'	20'	20'	24'	24'
11	Sight Tube - Lexan Tube	16'	16'	20'	20'	24'	24'
12	1" End Cap (Silicone to Lexan Tube)	1	1	1	1	1	1
13	Tube Clamps	5	5	6	6	7	7
14	1" Coupler (Silicone to Lexan Tube)	1	1	1	1	1	1
*15	Orange Indicator						
16A	Welded Brackets (Type A)	4	N/A	5	N/A	6	N/A
16C	Magnetic Brackets (Type C)	N/A	5	N/A	6	N/A	7
	Extended Brackets for Insulated or Bolted Tank	N/A		N/A		N/A	
17	Desiccant Bagged	1	1	1	1	1	1
*21	Cable Guide Two Pieces	1 SET	1 SET	1 SET	1 SET	1 SET	1 SET
22	1" x 3/4" Adapter (Place on Cable - Do Not Cement)	1	1	1	1	1	1
23	3/4" Coupler Cement to Cable Guide	2	2	2	2	2	2
*24	Clamping Block for PVC Guide Tube	1	1	1	1	1	1
	Clamping Block for S/S Guide Tube	1	1	1	1	1	1
25	Spring 3"	1	1	1	1	1	1
26	Washer PVC 2"	1	1	1	1	1	1
27	Aflas O-Ring	1	1	1	1	1	1
*30	PVC Guided Tube (2ft Longer than Tank)	18'	18'	22'	22'	26'	26'
31	Free Anchor Plate (Rubber Backing used with Type C)	N/A	1	N/A	1	N/A	1
31A	Fixed Anchor (2 Brackets/S.S Bolt)	1 SET	N/A	1 SET	N/A	1 SET	N/A
33	Magnetic Float	1	1	1	1	1	1
34	Cable / Follower (Bag with Indicator 8ft. Longer than Tank)	21'	21'	26'	26'	31'	31'
35	Anchor Adapter Assy. (Includes Nut/Bolt Attached to Anchor)	1 SET	1 SET	1 SET	1 SET	1 SET	1 SET
	Adapter/PVC Washer attached to Guide Tube						
	Hardware	14	16	16	30	22	38

**Optional**

- \*15 Indicator is Customized if Proximity Switch is Used  
Extended Brackets Are Used if Tank is Insulated or Bolted
- \*30 If S/S Guide Tube is Used Change the Following:
  - 2. Small S/S Spring and Washer are Used for the Base of the Guide Tube
- \*24 3. A Clamping Block for the S/S Guide Tube is Used or: A 1" Compression Fitting is Used Instead of a Clamping Block Assy.

# Specification Drawings

VISI-131Q (ABOVE GROUND SEALED)

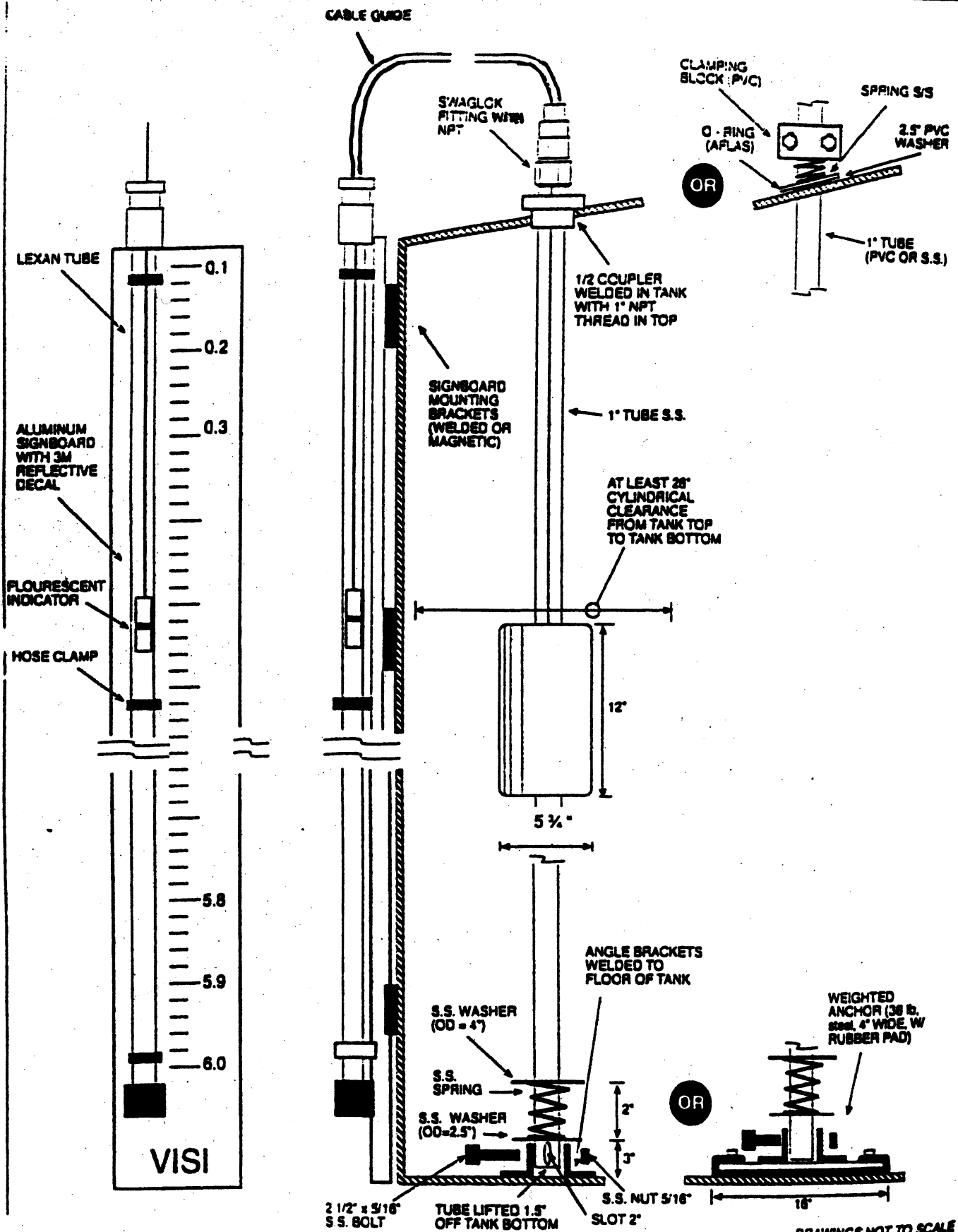

# TITAN-VISI 1310

ABOVE GROUND (SEALED)  
External Tank Gauge

*The Best Mechanical  
Liquid Level Gauge on the Market*

## FEATURES

- Easy factory or retrofit installation
- Wide temperature range
- Stainless steel or PVC materials
- Positive seal design
- Accurate to 2 cm
- 3M reflective material on signboard
- Signboard attached by weld-on brackets or magnets
- Low maintenance costs
- Few moving parts (no pulleys or shivs)
- Can be read from a safe and convenient distance
- corrosion resistant

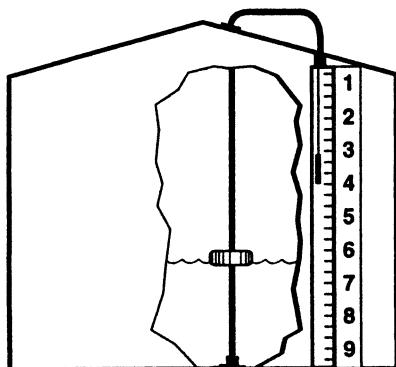

## TYPICAL APPLICATIONS

- Single tank
- Production batteries
- Refineries
- Portable/test tanks

## OVERVIEW

The Titan-VISI 1310 is a mechanical gauge that provides reliable and accurate readings in all weather conditions, and has been field-proven throughout North America for 12 years. It is particularly suitable for use in hazardous fluids or gases (including H<sub>2</sub>S) because it is completely sealed. One of the advantages of the VISI 1310 is the option of using either a welded bracket to secure the external

signboard or a high strength magnetic system. The magnetically secured system allows installation while the tank is in service. The signboard is made from 13 gauge aluminum and uses 3M reflective decals. Accuracy is within 2 cm. The external indicator on the VISI 1310 can also be used to activate proximity switches to control high/low level alarms or provide a signal to PLCs. In-tank components can withstand temperatures up to 110°C (230°F). Durable, corrosion resistant materials permit operation in a wide variety of environments, including: sour oil, sweet/waxy oil, drilling mud, refined petroleum products, raw sewage, water, strong acids and bases, salt water and alcohol. All in tank components are sealed, preventing fluid or vapor leakage from the tank, and moving parts have been kept to a minimum.

The low cost, ease of installation and reliability of the VISI 1310 make it a widely accepted product for above ground applications.

## PERFORMANCE

- **Fluid Monitored**
  - crude oil (sweet, sour)
  - condensate
  - water
  - drilling mud
  - chemicals
  - acids, bases
  - refined petroleum
  - heavy crude
  - salt water
  - sewage
- **Measurement Range**
  - 7" to 33 ft
  - optionally to 50 ft
- **Accuracy**
  - resolution: 2 cm
  - linearity: absolute
- **Response time**
  - 0.1 seconds to settling

- **Pressure**
  - ≤ 15 psi: standard float (50 psi instantaneous)
  - > 15psi: special floats available
- **Temperature range**
  - Proximity Switches (optional):
    - -40°C to +105°C
  - Tank internals:
    - standard: to 65°C
    - optional: to 110°C
- **Maximum Cable Guide Length**
  - 1 ft to 20 ft tank: 14 ft
  - 20 to 33 ft tank: 8 ft

## MECHANICAL

- **Materials**
  - Tube
    - standard: PVC
    - optional: 304 S.S.
  - Float: 304 S.S. w/3M Scotchkote 134
  - Tube Anchor: S.S., carbon steel, aluminum (customer specified)
  - Swaglok fitting: carbon steel or 316 S.S.
  - Signboard: aluminum
  - Cable Guides: PVC
  - Site Tube: Lexan
- **Anchor Types**
  - rubber coated free weigh (38lb)
  - angle brackets (welded)
- **Float**
  - standard float (FRP 5 3/4" x 12" - Other floats available)

## OUTPUT OPTIONS

- **Proximity Switch (optional)**
  - easily field programmable over entire range of tank

## APPROVALS/CERTIFICATION

- Proximity Switch/CSA (Class 1, Div Grps B,C,D)
- Specifications subject to change without notice

# Level & Flow Proximity Switch



## MLS - 3 EX Latching Proximity Switch

The MS - 30 is a hermetically sealed bi-stable latching reed switch with SPDT form C contacts. The switch is actuated by the float and latches, this maintaining the contact after the float continues to rise or fall with level. The MLS-3 EX comes with an explosion proof enclosure with an internal terminal block and is ideally suited for low power alarm signals.

### Specifications

Deadband	0.50 inch
Max. Temp.	650° F (343° C) HT version 350° F (177° C) STD version
Min. Temp.	- 40° F (- 40° C)
Contacts	Form C SPDT
Volts AC	150 AC/DC
AC Current	1.0A AC/DC
Watts	25 W DC/VA

**Note:** Because of the low current of the switch rating a higher rated interposing relay should be used between the MLS-3EX and the device being switched.

### Schematic

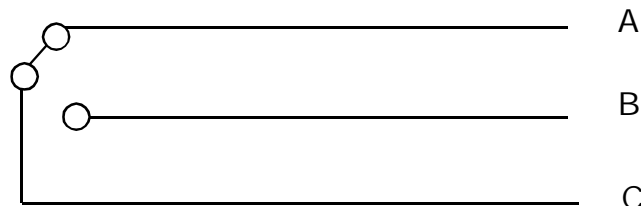

### Switch Operation / Mounting

To mount the MLS - 3EX Level Switch simply clamp it directly to the side of the level gauge sight glass using the adjustable hose clamps provided. Alarm set points may be changed by simply loosening the clamps and sliding the switch to the desired alarm level. To set up starting point follow the steps below:

#### Rising Level Alarm -

Terminal Block Letter:  
A (NC) C (Common) B (NO)

#### Falling Level Alarm -

Terminal Block Letter:  
B (NC) C (Common) A (NO)

After the switches are mounted and wired, they need to be set to the desired state for rising and falling level as noted previously. This is easily accomplished by either manually pushing the indicator or a magnet past the highest switch, or by carefully monitoring the gauge / switch operation while filling the tank.

Formerly Titan Technologies • Sherrex Systems • Nagy Burner Control • Alberta Industrial Technologies

**Head Office** 4130 - 93 Street, Edmonton, Alberta T6E 5P5 P: (780) 462-4085  
**Saskatchewan Branch** Box 460, 103 Cenaiko Street, Lampman, Saskatchewan S0C 1N0 P: (306) 487-2883  
**Calgary Sales Office** Box 306, #440 10816 Macleod Trail S., Calgary, Alberta T2J 5N8 P: (403) 251-5797



[www.titanlogix.com](http://www.titanlogix.com)

# Level & Flow Proximity Switch

## Mounting

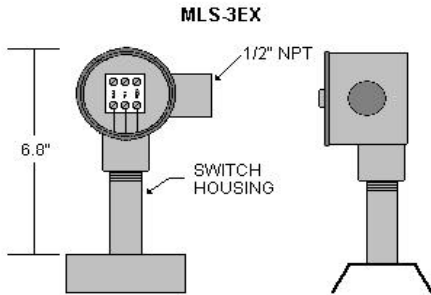

The simplicity of mounting the MS-30 switch housing is such that a small screwdriver is the only necessary tool. The MS-30 is mounted using two stainless steel clamps that pass through the mounting slots attached to the housing and around the chamber. Other switches can be added at any position at anytime without concern for additional process piping or valves. Two switches can be mounted so that they can trip at the same point or at two different points separated by less than the length of a switch.

## Specifications:

Switch	Magnetically activated, hermetically sealed, magnetically biased bistable reed switch. Single pole double throw-form C.
Switch Action	Break before make
Contact Material	Rhodium
Max Deadband	Approx. +/- 0.075" float travel
Max. Switch Voltage	250 VAC (250 VDC)
Max. Switch Current	1 amp (AC/DC)
Max. Switch VA	250 VA (250 watts resistive)

Formerly Titan Technologies • Sherrex Systems • Nagy Burner Control • Alberta Industrial Technologies

Head Office 4130 - 93 Street, Edmonton, Alberta T6E 5P5 P: (780) 462-4085

Saskatchewan Branch Box 460, 103 Cenaiko Street, Lampman, Saskatchewan S0C 1N0 P: (306) 487-2883

Calgary Sales Office Box 306, #440 10816 Macleod Trail S., Calgary, Alberta T2J 5N8 P: (403) 251-5797



[www.titanlogix.com](http://www.titanlogix.com)

# VISI 1310 - SOUR SERVICE

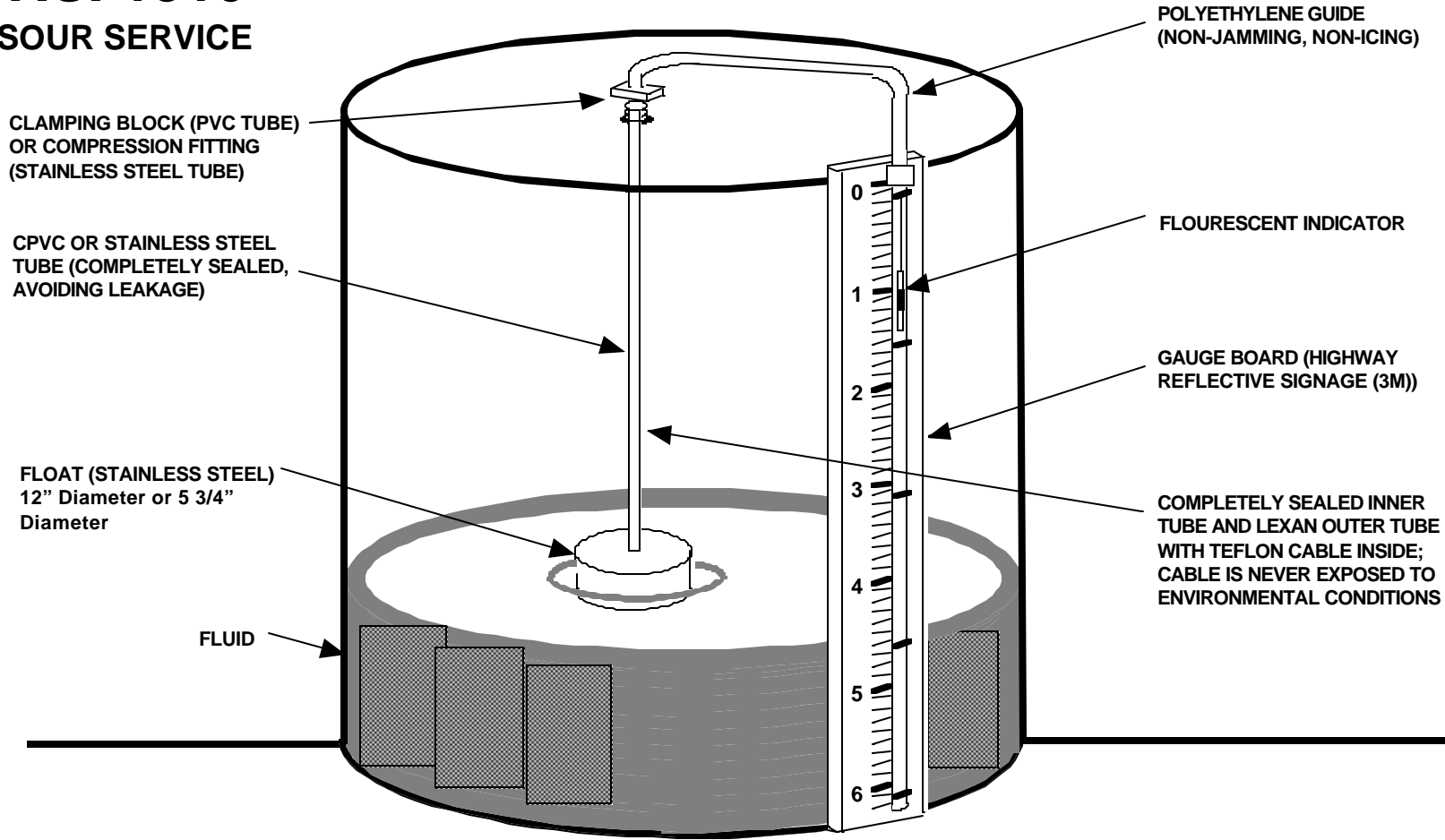

(NOT TO SCALE)

	TITAN LOGIX CORP. EDM - 780-462-4085 SK 306-484-2883
	CAN BE INSTALLED "IN SERVICE" THROUGH A STANDARD 8" THIEF HATCH
	<a href="http://www.titanlogix.com">www.titanlogix.com</a>

# VISI 1310 for Storage Tanks

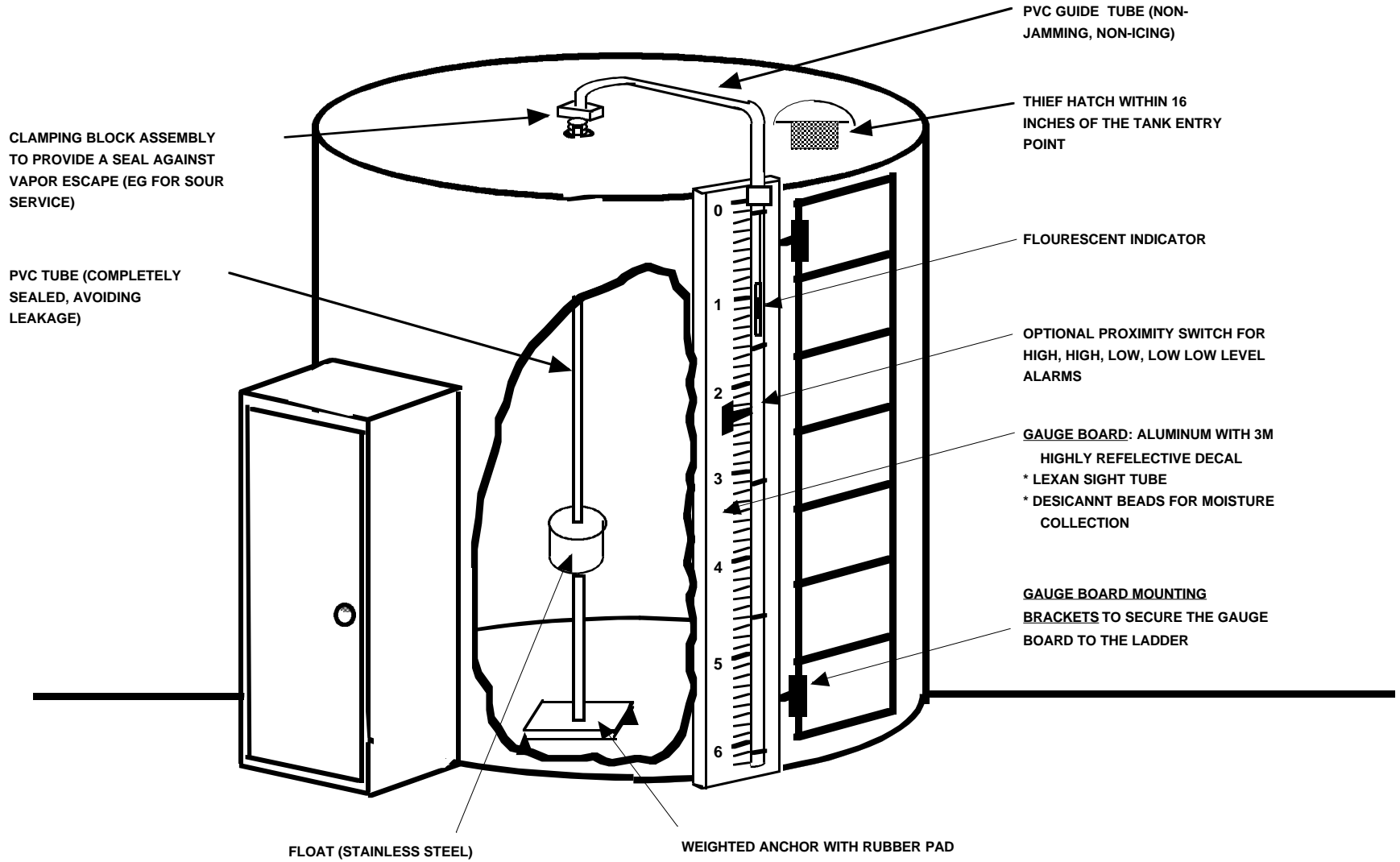

instrumentation solutions that just make sense  
 Edmonton, AB P: 780-462-4085    Lampman, SK P: 306-487-2883