



Warranty Statement

WARRANTY: Titan Logix Corp. warrants all equipment of its own manufacture to be free of defects in material and workmanship for a period of twelve (12) months from date of shipment. Titan Logix Corp. sole obligation hereunder shall be expressly limited to repair or exchange free of charge, F.O.B. Edmonton, Alberta, Canada, of such defective equipment (alternatively, Titan Logix Corp. will, at its option, refund the purchase price). Titan Logix Corp. obligation under this warranty is limited to the above and does not apply to exchange or repairs, which are required as a result of improper installation, misuse, maladjustment, abnormal operating conditions, or lack of routine maintenance. Nor does the warranty include the furnishing of service for maintenance or problems arising from the foregoing causes. No claims for labour, installation, removal, transportation, or other expenses will be recognized. Notwithstanding any stipulation of the purchaser to the contrary, all other obligations, representations, warranties and conditions, express or implied, statutory or otherwise, including any implied warranties or conditions of merchantability, quality or fitness are hereby excluded and Titan Logix Corp. shall not be liable for any loss, cost or damages, of any kind whatsoever, whether consequential, indirect, special or otherwise, arising out of or in connection with the equipment or any defect therein, even if caused by the negligence of Titan Logix Corp., its employees or agents. The provisions hereof relating to the warranty and limitations hereon and limitation of liability shall continue to be enforceable between the parties notwithstanding termination of the within agreement for any reason including fundamental breach. Equipment not of Titan Logix Corp. manufacture will carry the vendor's or manufacturer's standard warranty.

©2010 Titan Logix Corp.
Part # 1200-0008



At Titan, we strive to design equipment that is simple to use and reliable in its operation, with the aim of satisfying our customers' needs.

Titan Logix Corp. areas of expertise include:

- **Level and Flow measurement**
- **Transport Instruments**
- **Burner and Combustion**
- **Communication and Control System Integration and**
- **Drilling Fluid Monitoring**

We have been designing and manufacturing electronic equipment since 1980. Titan Logix Corp. unites four companies – each a leader in different segments of the oil and gas industry:

- **Titan Technologies**
- **Nagy Burner Control (NBC)**
- **Sherrex Systems**
- **Alberta Industrial Technologies (AIT)**

Titan Logix Corp. sells and markets through distributors, and representatives. Through continuous improvement, we are striving to provide our customers with first-rate sales information, engineering assistance, and after-sales support.

For more details on our products and services, please visit our website at www.titanlogix.com or contact us and we will provide you with a listing of the offices or representatives nearest you.

Table of Contents

INTRODUCTION	1
ABOUT THIS MANUAL	1
ABOUT THE 3500 CONTROLLER.....	2
MAIN FEATURES	2
INSTALLATION	3
ENVIRONMENTAL	3
OUTLINE	4
OPERATION	6
SOFTWARE OPERATION	7
Screen Matrix	8
Tank Screens (J3 Not In).....	9
Controller Settings Screens (J3 Not In)	10
Tank Screens (J3 In).....	11
Controller Settings Screens (J3 In).....	13
EDITING SCREENS	14
OUTPUT CARD OPERATION	15
Pump Start Stop.....	16
High Level Alarm.....	16
Low Level Alarm	16
Timeout Contact.....	16
Loss of Power Contact.....	16
INPUT CARD OPERATION.....	17
Pulse Input	17
WIRING	18
SPECIFICATIONS.....	19
TROUBLESHOOTING	20

Introduction

About This Manual

This instruction manual provides information specific to the Titan Logix Corp. 3500 Controller. Other peripheral equipment should be supplied with its own instruction manual and that manual should be referred to for proper operation of the peripheral equipment.

It is essential that this manual be read and understood for proper installation and operation of your 3500 Controller.

This manual includes:

INTRODUCTION:	Briefly describes the key features of the 3500 Controller.
INSTALLATION:	Detailed description of mounting and wiring of equipment.
OPERATION:	Describes the operation and use of the features of the 3500 Controller.
PROGRAMMING:	Describes the procedures for programming the 3500 Controller.
WIRING:	Describes how to connect the 3500 Controller to the power supply, level gauges, communication systems, and output devices.
SPECIFICATIONS:	Describes the physical and operational characteristics.
TROUBLESHOOTING:	Describes several quick problem-solving techniques.

About the 3500 Controller

The 3500 Level Controller provides continuous monitoring of liquid levels in tanks using a TPZ 3310 level gauge. Up to eight tanks can be monitored. Along with monitoring it can also control the liquid level by the user programmable Pump Start and Pump Stop set points.

High and Low Level Alarm contacts are also provided in the 3500 Level Controller. Depending on user preference the High and Low Level Alarm contacts can alternatively be configured as a High and High-High Level alarm contacts. These contacts can be connected to audible or visual alarms to provide operator alerts.

All relay contacts may be set for N.O. or N.C. operation. On loss of power the level last read by the 3500 is stored in battery backed up RAM.

Main Features

Enclosure:	NEMA 4, Fire Retardant Fiberglass.
Input:	Pulse input for up to 8 tanks. 0-5KHz at a minimum 200 μ S pulse width.
Output:	Four (4) dry contact FORM C relays for each of 8 tank zones. Each relay is rated for 2Amps at 30 VDC.
Display:	Tank level and Alarms are displayed on a 2 x 20 line Vacuum Fluorescent (VFD) display.
Reliability:	Built using industrial specified components to ensure long life and reliability even in harsh conditions.
Programming:	The 3500 controller can be programmed by the operator. The programmable features are high and low alarms, pump start and stop levels, and tank level values.

Installation

Installation should only be performed by qualified personnel and in accordance with local governing regulations. Observe all required safety practices as set forth by site operators and OH&S regulations.

Environmental

Choose a mounting location suited for the 3500 Controller.

The ideal 3500 Controller mounting location is where the:

1. Mounting surface has minimal vibration.
2. Ambient temperature is always within -40°C to $+65^{\circ}\text{C}$ (-40°F to $+149^{\circ}\text{F}$).
3. Cable lengths are minimal.

Avoid mounting locations where the 3500 Controller is:

- Close to high voltage/current runs, contactors, SCR control devices, or frequency inverters.

- strain relief holes to be drilled using a hole saw (be careful to avoid internal damage when doing so)

- strain relief holes should be located on the underside of the enclosure

Outline

Figure 1 (3500 Controller Enclosure)

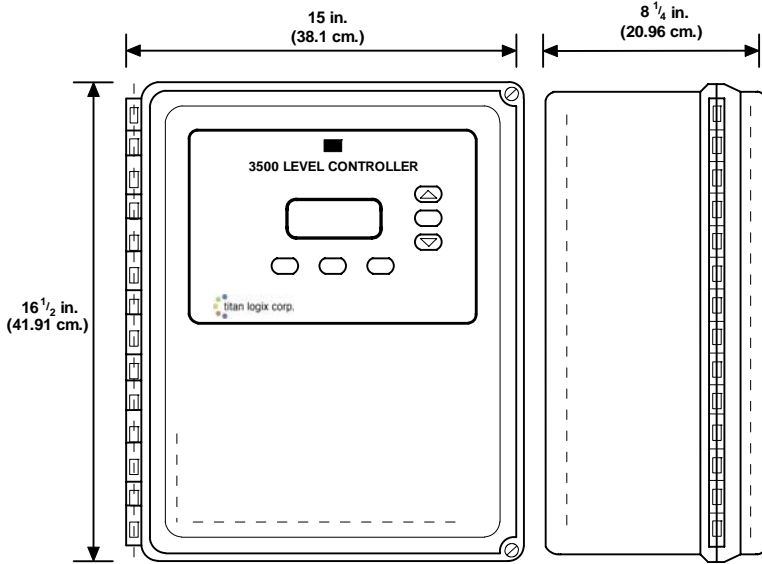

Figure 2 (3500 Controller Output / Input Cards)

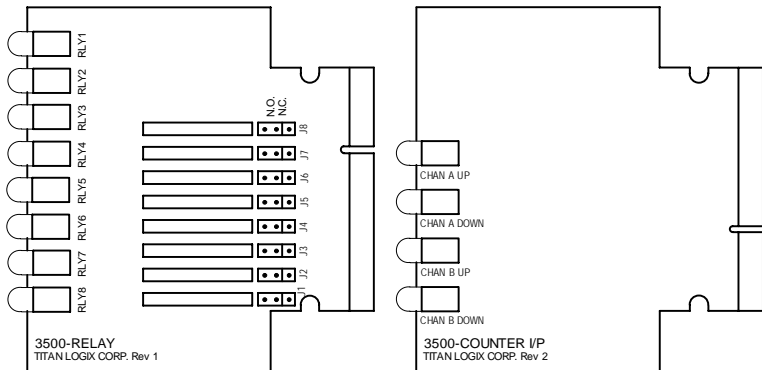

Figure 3 (3500 Controller Terminal Card)

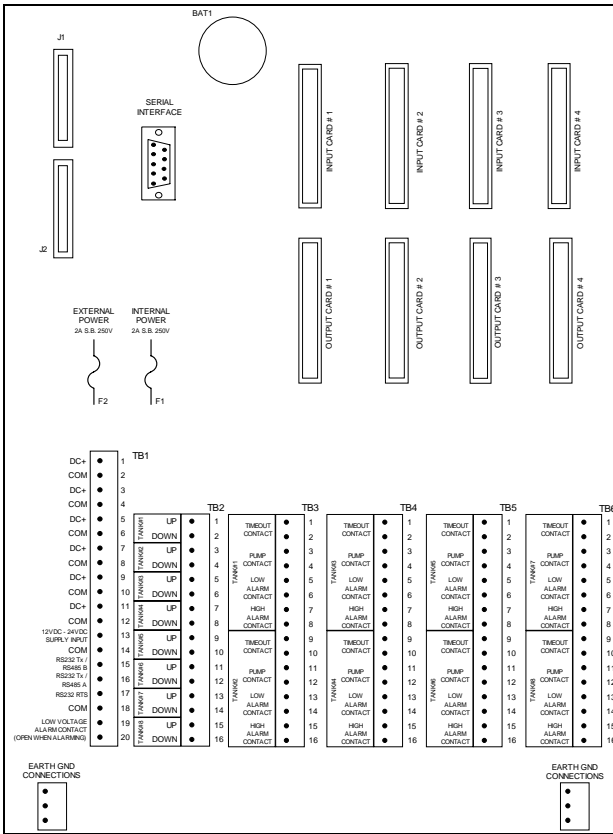
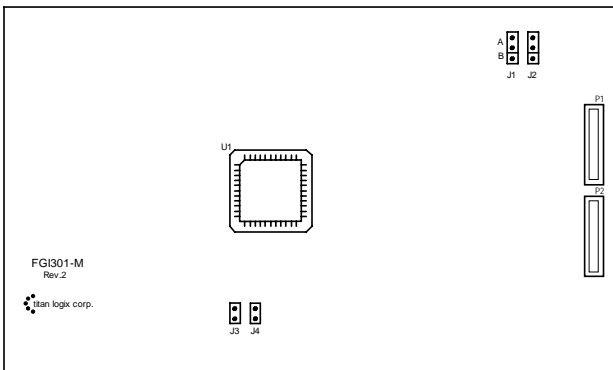

Figure 4 (3500 Controller CPU Card)



Operation

Refer to figure 5 below for the locations of the keys and indicators referred to throughout the remainder of the manual.

Figure 5 (3500 Controller Display Overlay)

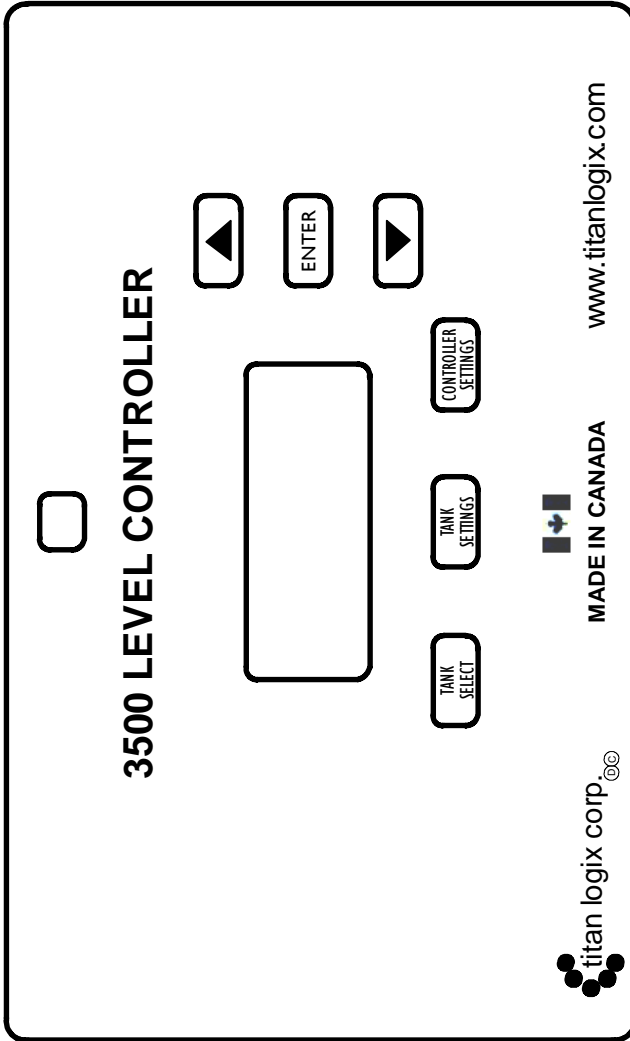

Software Operation

After power is applied to the 3500, each gauge zone must be set up. Six buttons are located on the front panel to navigate and alter values in some of the screens.

Buttons

Tank Select - This button allows the operator to cycle through the settings for all the gauges wired into the 3500 controller. When the button is pressed the Tank Screens menu (Figure 6) will be reset to the first screen.

Tank Settings – This button allows the operator to cycle through the settings for that tank selected. If jumper J3 on the 3500 CPU Card (Figure 4) is in, this menu is expanded so that all the operating variables for that tank may be edited.

Controller Settings - This button allows the operator to cycle through settings that are related only to the 3500 controller and not the tank. If jumper J3 on the 3500 CPU Card is in, this menu is expanded so that the operator may configure these settings.

Up Arrow - Increments digits in screens that are editable.

Down Arrow - Decrements digits in screens that are editable.

Enter – This button saves the digit being edited and allows editing of the next digit. To save the entire value the enter character (↵) must be displayed at the end of the value being edited, then the enter button must be pressed to save the entire value to the non-volatile memory. The value loaded will then be displayed on the screen.

Screen Matrix

Three buttons are used to navigate through the screens; Tank Select, Tank Settings, and Controller Settings.

The Tank Select button when pressed will cycle the display from Tank#1 to Tank#8 depending on how many input cards installed. Each input card represents two tanks.

The Tank Settings button will navigate through the settings for the tank that was selected by the Tank Select button. Please refer to Figures 5 and 6.

Figure 6 (3500 Controller Screens)

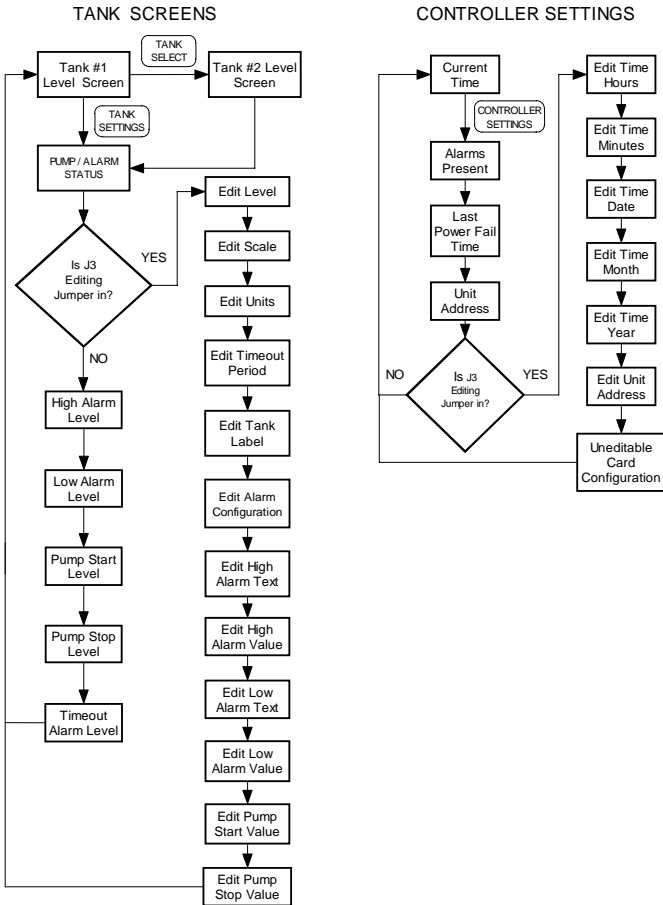

Tank Screens (J3 Not In)

Figure 7 (Tank Screen Matrix, J3 Not In)

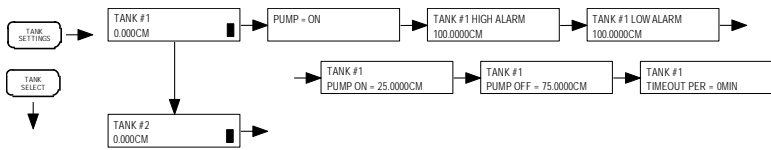

Main Level Screen - This screen displays the current level of the tank with the current units.

Pump / Alarm Status Screen - This screen displays the current pump and alarm status.

High Alarm Level - The current High Alarm Level setting is displayed.

Low Alarm Level - The current Low Alarm Level setting is displayed.

Pump Start Level - This display indicates at what level the pump is to turn on at. If the volume is greater then the indicated volume the pump will turn on. If the Pump Start Level is higher then the Pump Stop Level the pump contact will turn on to drain the tank of fluid. If the Pump Stop Level is higher then the Pump Start Level the pump contact will turn on to fill the tank with fluid.

Pump Stop Level - This display indicates at what level the pump is to turn off at. If the volume is greater then the indicated volume the pump will turn on. If the Pump Start Level is higher then the Pump Stop Level the pump contact will turn on to drain the tank of fluid. If the Pump Stop Level is higher then the Pump Start Level the pump contact will turn on to fill the tank with fluid.

Timeout Alarm Period - The time that is used for a Up/Down pulse timeout is displayed. If a Pulse from either the up or down counters is registered within the user defined timeout period the output relay will be energized.

Controller Settings Screens (J3 Not In)

Figure 8 (Controller Settings Screen Matrix J3 Not In)



Current Time - The time that is stored in the Real Time Clock.

Alarms Present - This is a scrolling screen that displays all the alarms after 5 seconds. The alarms displayed are all the tank alarms and system alarms.

Last Power Fail Time - Displayed is the time and date the last power fail occurred.

Unit Address - The unit address is used for the RS232/RS485 communications port. It is the assigned Modbus address for the unit.

Tank Screens (J3 In)

Figure 9 (Tank Screen Matrix J3 In)

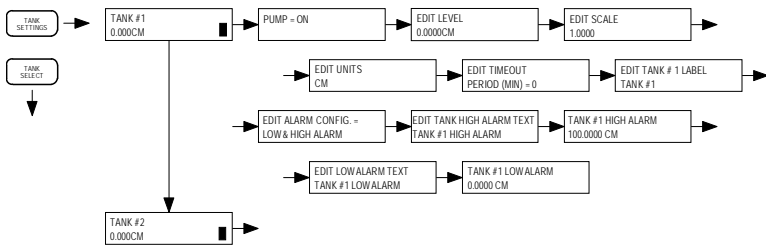

J3 on the Main CPU card located on the 3500 Controller door must be **IN** for the 3500 Controller to enter Edit Mode. (Refer to Figure 4)

Edit Level - This allows the current Level of the selected tank to be edited in the appropriate units.

Edit Scale - The Scale or K-Factor is the conversion factor for one pulse count to an equivalent volume.

Edit Units - CM, FT, BBLs, M3, GAL, or L may be selected. The UP and DOWN arrows will just cycle through these units rather than loading one character at a time. The ENTER button will save the units rather than the ↵ symbol.

Edit Timeout Period - If no change in the counter inputs occurs for the length of the Timeout Alarm the Timeout Alarm contact will close. The time entered here is in 1 minute intervals and a value of 0 will disable the Alarm.

Edit Label - Each tank can have its own unique label that describes the tank function.

Edit Alarm Configuration - This screen allows the user to control how the two level alarms are to operate. The system can operate with either a Low and High Alarm or a High and High-High Alarm. Each tank has the ability to be configured either way.

Edit High Alarm Text - Special text may be entered here for the High Level Alarm values.

Edit High Alarm Value - The High Level Alarm contact will be activated at this level. The level should be in the appropriate units.

Edit Low Alarm Text - Special text may be entered here for the Low Level Alarm values.

Edit Low Alarm Value - The High Level Alarm contact will be activated at this level. The level should be in the appropriate units.

Edit Pump Start Value - The Pump contact will be activated at this level. The level entered should be in the appropriate units. If the Pump Start Value is higher than the Pump Stop value the pump contact will close to empty the tank. If the Pump Stop value is higher than the Pump start value the pump will fill the tank.

Edit Pump Stop Value - The Pump contact will be activated at this level. The level entered should be in the appropriate units. If the Pump Start Value is higher than the Pump Stop value the pump contact will close to empty the tank. If the Pump Stop value is higher than the Pump start value the pump will fill the tank.

Controller Settings Screens (J3 In)

Figure 10 (Controller Settings Screen Matrix J3 In)

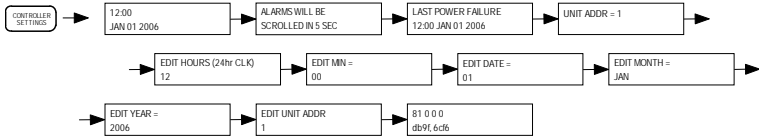

If J3 on the Main CPU card is IN that allows the screen to continue on with the Editing screens. If the Jumper is OUT the display will go back to the Current Time Screen.

Edit Hours - This adjusts the hours on the real time clock. The clock is a 24hr clock not two 12hrs. The Enter button saves the adjusted value.

Edit Minutes - The up and down buttons are used to adjust the value between 0 and 59. The Enter button saves the adjusted value.

Edit Date - The up and down buttons are used to adjust the value between 0 and 31. The Enter button saves the adjusted value.

Edit Month - The up and down buttons are used to adjust the value between Jan and Dec. The Enter button saves the adjusted value.

Edit Year - The up and down buttons are used to adjust the value between 2004 and 2099. The Enter button saves the adjusted value.

Edit Unit Address - A value between 1 and 16 may be loaded here to indicate the Modbus Communication Address for the 3500 system.

Card Configuration - This is a diagnostic display indicating what input and output cards the 3500 has internally detected. A counter board input with a relay board output will read 81 hex.

Editing Screens

To be able to reach the editing screens J3 must be in on the CPU card (Figure 4). When a screen is editable the first number or letter in the string that can be altered will flash. The UP and DOWN buttons will cycle through the appropriate characters until the desired character is reached. The character sets are...

NUMERIC: 0 1 2 3 4 5 6 7 8 9 . ↵

ALPHANUMERIC: sp ; “ # \$ % & ‘ - . / 0 1 2
3 4 5 6 7 8 9 : ; < = > ? @
A B C D E F G H I J K L M
N O P Q R S T U V W X Y Z
↵

UNITS: CM FT BBL M3 GAL L

When the desired character is reached press the ENTER button. This will cause the next character to flash. When the edited value is correct, cycle through characters until the symbol “↵” is reached and press ENTER.

If there are characters after the “↵” they will be dropped when the edited value is saved by pressing the ENTER button. The value saved will be reloaded to the display with the first character flashing again. This is done to easily correct any errors in loading the value the first time.

Output Card Operation

The 3500 controller can be equipped with up to 4 output cards. Each output card will control the alarm contacts for two tanks. Each tank will have 2 level alarms as well as a contact for pump control and a timeout contact. 8 LED's are located on the top of each output card to indicate the status of each individual relay and jumpers are located behind the relays for user settable N.O. or N.C. operation (Factory sent out N.O.). J1 corresponds to RLY1 etc. The LED for the corresponding alarm will be illuminated when the relay is energized or closed.

Figure 11 (3500 Controller Output Card)

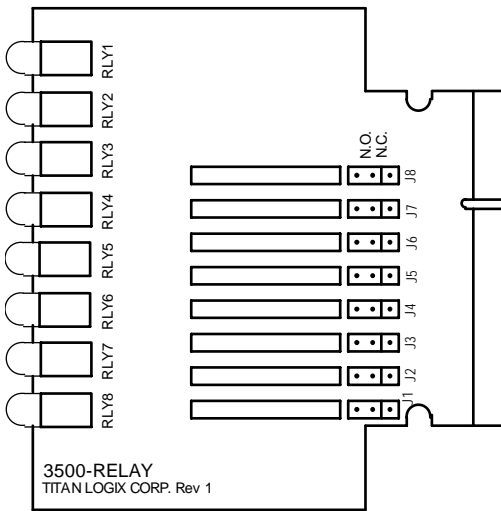

Pump Start Stop

The volume of each TPZ Level Transmitter is compared to the Pump On and Pump Off set points. If the volume goes above or below those set points action is performed on the pump output contact.

High Level Alarm

If the volume exceeds The High Alarm set point the High Alarm contact will be energized.

Low Level Alarm

If the volume is less then the Low Alarm Set point the Low Alarm relay will be energized. All three relays have N.O. or N.C. jumper positions.

Timeout Contact

If the volume remains unchanged over a preprogrammed period of time the Timeout relay will be energized. If the timeout period is set to zero then this function is disabled.

All the relays are capable of switching 3A at 24VDC except for the loss of power relay which only capable of switching 100mA at 24V.

Loss of Power Contact

A low power photovoltaic relay is provided to indicate that a low power situation has occurred. This is a N.C. contact rated for 100mA at 120V. On loss of power the level last read by the 3500 is stored in battery backed up RAM.

Input Card Operation

The 3500 controller can be equipped with up to 4 input cards. Each input card will accept pulse up and down inputs from 2 TPZ 3310 Level Transmitters. 4 LED's are located on the top of the 3500 Controller input card to indicate connection to the appropriate pulse input. The LED will be on when the pulse input is tied in correctly.

Figure 12 (3500 Controller Input Card)

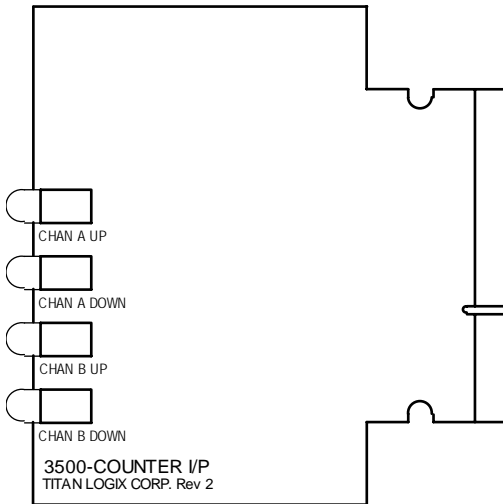

Pulse Input

The input card of the 3500 Controller is designed to accept the pulse up and down outputs from the TPZ 3310 level transmitter. The TPZ 3310 level transmitter will be equipped with 1 of 3 Titan Logix Corp. circuit boards.

1. LOON CARD – Capable of a pulse output, 4-20mA output and SVBUS Communication.
2. BLUEBIRD CARD – Capable of a pulse output and SV communication.
3. PULSE CARD – Capable of a pulse output.

The Pulse input card is capable of a pulse input of 0-5KHz at a minimum pulse width of 200 μ S. The 3500 Controller software can sample up to 1250 pulses per second.

Wiring

Figure 13 (3500 Controller Complete Wiring)

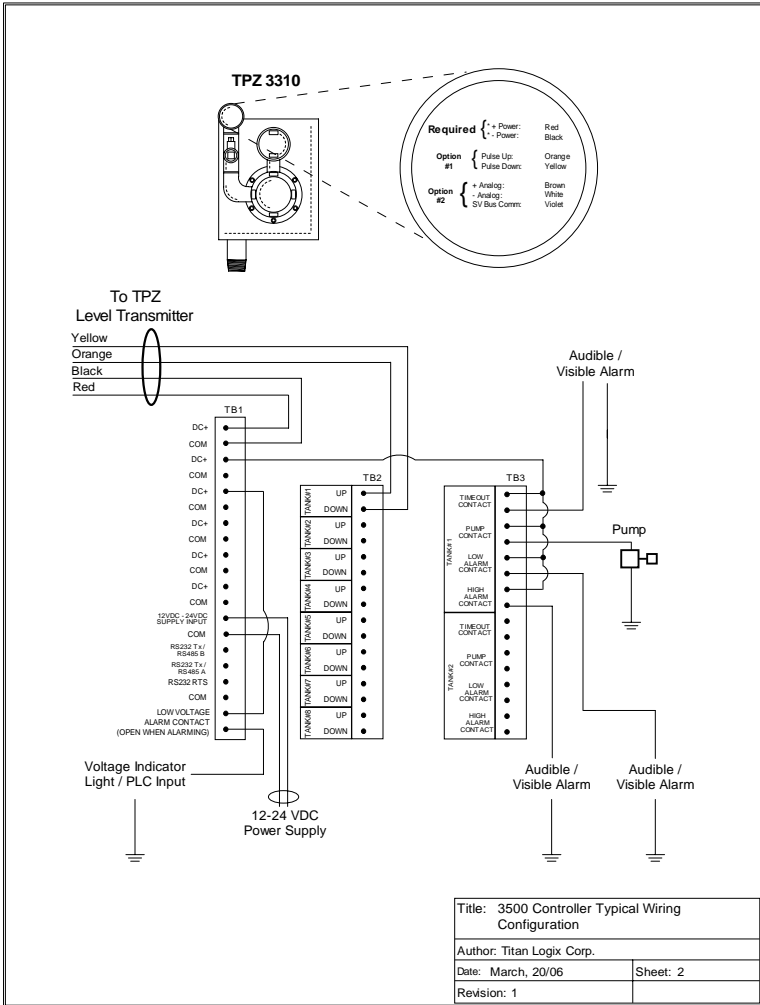

Specifications

3500 Controller

Approvals Class I, Div. 2, Hazardous Locations Groups C&D T3

Operating Temperature : -40°C to +65°C
(-40°F to +149°F)

Average Current Consumption: 750mA

Pulse Input: Frequency Range 0-5KHz
Minimum pulse width of 200µS

Case: NEMA 4

Relay Output: The relay dry contact output may come from an incendive source and must be investigated to maintain DIV. 2 – 5AMP Max, 24VDC

Troubleshooting

Problem	Possible Solution
Incorrect Level Displayed	<ul style="list-style-type: none">• Ensure correct scale is entered• Ensure TPZ 3310 Level Transmitter is wired correctly• Ensure Optical disk and reader are operating properly in the TPZ 3310 Level Transmitter
Timeout contact continues to trip	<ul style="list-style-type: none">• Ensure that 0 is selected under the edit timeout period screen with J3 in.