

TD80™ / Finch 5332 DUAL ROD PROBE OPERATION MANUAL

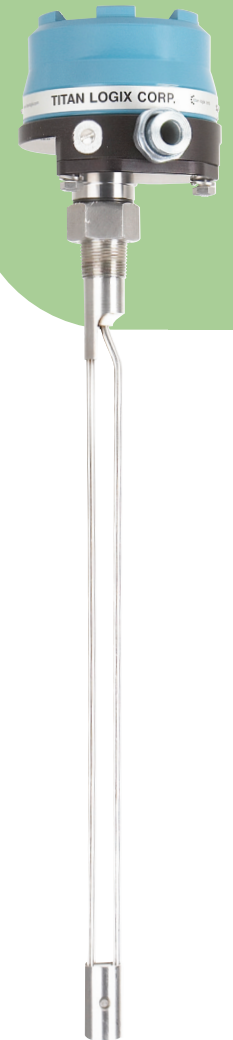

Manufactured in Canada



Manufactured by:



Head Office

4130 – 93 Street
Edmonton, Alberta
Canada T6E 5P5
P 780.462.4085
F 780.450.8369

Saskatchewan Branch

Box 460 103 Cenaiko Street
Lampman, Saskatchewan
Canada S0C 1N0
P 306.487.2883
F 306.487.2889

Kansas City Branch

Suite 205
140 Walnut Street
Kansas City, Missouri 64105
P 816.214.6049
F 816.214.6044

Toll Free 1.877.462.4085 | TSX-V: TLA

Sales Department: Email us at sales@titanlogix.com

Service Department: Email us at service@titanlogix.com

Find us online at www.titanlogix.com



Creating Instrumentation Solutions - Everyday

TROUBLE SHOOTING

Problem	Possible Solution
Horn Circuit OK LED is not on.	Check that the horn is wired properly. Replace the fuse for the horn Replace the horn
Horn Circuit OK LED is blinking. Or Faint beeping coming from horn.	Check that the horn is wired properly. Check for loose wires. Place a 150ohm to 500ohm resistor across the horn Replace the horn with a less sensitive one.
Display does not turn on.	Check that the input power fuse is not blown. Check that the power is wired correctly. Check for loose wires.
Only the decimal point appears on the display.	The display is faulty, replace it.
Display shows only "- - - -"	Communications between the level transmitter and the display have been interrupted. Check the wiring between the display and transmitter. Possibly a faulty level transmitter
Display registers highest level point all the time, even when empty.	Tank has been over filled, pump out excess fluid immediately. Reset the Spill bit in the transmitter. (see Spill Alarm section of this manual)
Large offset or error.	Unit may be faulty or strapping table is incorrect, contact your distributor.
Display shows "2 LO" during calibration	Power down the system, add more fluid to the tank. Recalibrate. (see Calibration section of this manual)
Display shows "SPill"	Tank has been over filled, pump out excess fluid immediately. Reset the Spill bit in the transmitter. (see Spill Alarm section of this manual)

Table of Contents

CONTACT INFORMATION	2
OPERATION	3
CALIBRATION	4
MODES OF OPERATION	5
<i>ALARM DISABLE MODE</i>	<i>5</i>
<i>DISPLAY MODE</i>	<i>5</i>
<i>MONITOR MODE</i>	<i>6</i>
<i>SET FILL/FALL MODE</i>	<i>6</i>
ALARMS	7
<i>FILL/FALL ALARM</i>	<i>7</i>
<i>HIGH/HIGH ALARM</i>	<i>7</i>
<i>FAIL ALARM</i>	<i>8</i>
<i>SPILL ALARM</i>	<i>8</i>
<i>DISABLING 2LO</i>	<i>8</i>
WIRING	9
<i>TRANSMITTER POWER/SVBUS</i>	<i>9</i>
<i>PTO AND EXTERNAL ACKNOWLEDGE</i>	<i>10</i>
<i>HH ALARM RELAY OUTPUT</i>	<i>11</i>
<i>FILL ALARM RELAY OUTPUT</i>	<i>12</i>
<i>FAIL ALARM RELAY OUTPUT</i>	<i>13</i>
<i>POWER INPUT</i>	<i>14</i>
TD80 PROBE	15
TROUBLE SHOOTING	16

CONTACT INFORMATION

Head Office

4130 – 93 Street
Edmonton, Alberta
T6E 5P5
P (780) 462-4085 / (877) 462-4085
F (780) 450-8369

Saskatchewan Branch

Box 460, 103 Cenaiko Street
Lampman, SK
S0C 1N0
P (306) 487-2883
F (306) 487-2889

USA Branch

Suite 205
140 Walnut Street
Kansas City, Missouri
64105
P (816) 214-6049
F (816) 214-6044

For any field product support or service, please contact one of our offices for contact information on the service rep. in your area.

TD80 PROBE

The TD80 probes alarm points will be as follows.

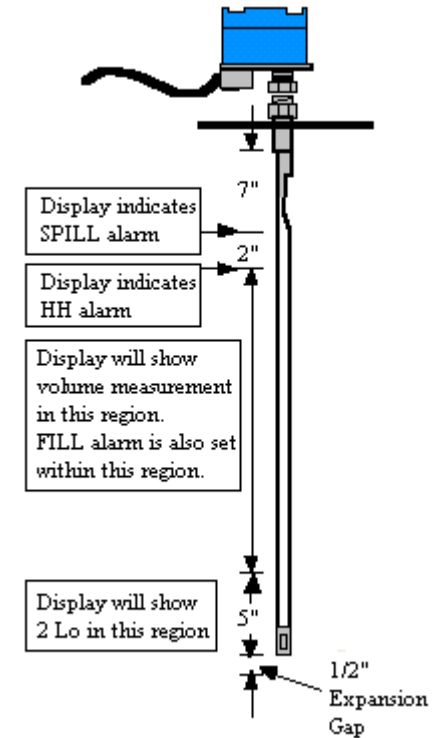

For the TD80 probe to function efficiently and accurately, the following must be applied.

- The probe inside the must be free from obstruction from any foreign solid objects, including build up caused by excessive use in thick fluid applications.
- The transmitter on the top of the tank must be tight and secured to the probe with no free movement.
- The probe must be free from any bending, and the two rods must be separate at all times, from the transmitter to the cone in the bottom of the tank.

POWER INPUT

Before applying power to the Finch Display ensure the supply is set to a voltage the unit can accept, otherwise damage to the Finch Display and Level Transmitter is very likely. Before applying power to the Finch Display for the first time, ensure any related alarm/control equipment is disabled until satisfactory system operation and performance is verified. The Finch Display is designed to operate from 8 to 28VDC. For transport applications it is recommended that the unit be powered from the vehicle's accessory power.

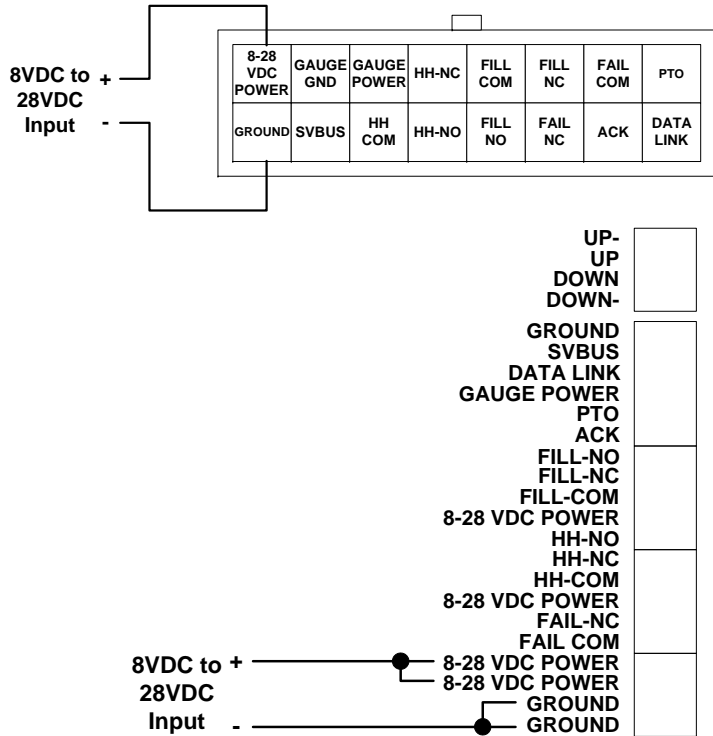

OPERATION

The finch display constantly receives level information from a level transmitter, which is attached to the probe in the tank. The level transmitter contains a strapping table, which allows it to convert the measurements it takes into useable units. The level transmitter also contains the information for the HH Alarm and the Spill Alarm levels. These levels are predetermined within the software and are not user settable. The finch display contains the information for the fill alarm, which can be changed at any time to suit the need of the user. This also allows any faulty displays to be changed out without losing any strapping table information about the tank itself.

Start Up

When power is applied to the finch display, the level transmitter will be fed power from the display itself. The level transmitter will run through a 12 second, diagnostic test to ensure the information it transmits correct. During the transmitter's diagnostic cycle the Finch Display will run its own diagnostic, during which the Finch display will show the current software revision number followed by a display test consisting of all four digits showing the values from 0 to 9 and A to F. At the same time as the display test, the unit will test the Fill and Fail relays. The unit will wait 2 seconds, pulse the Fill relay for 1 second, wait for 2 seconds, and pulse the Fail relay for 1 second.

During start up, the operator may force the unit into calibration mode (see Calibration section for more information) by pressing either of the front panel buttons while turning the power on. If no button press is registered the unit will enter its normal mode of operation (either Monitor Mode or Off Mode Depending on PTO condition).

Note: If the display diagnostic is completed before the transmitter diagnostic the unit may display four dashes (----) for a few seconds while the transmitter diagnostic completes.

CALIBRATION

In order to perform a calibration on the system a known amount of fluid must be in the tank. This level must be greater than 6 inches or the system will be unable to read the level accurately enough to perform the calibration.

To enter calibration mode, the displays PTO switch must be turned on. If the display does not have a PTO switch, it is wired such that it is always on. Before powering up the unit, the operator must hold down either of the buttons on the front of the display. While continuing to hold down either of the buttons, the operator must apply power and continue to hold down the button throughout the displays diagnostic cycle. Once the cycle is complete, the display will flash CAL.



The unit will flash CAL for a few seconds to indicate that it has entered calibration mode, and it will then show the current level of liquid in the tank. If the current measurement displayed is not valid for what is in the tank, the operator may change the reading at this time by pressing the up or down arrow until the displayed value is correct. All alarms in the transmitter are cleared at this time. If there is not enough fluid in the tank the display will flash 2 LO.



More fluid will need to be added to the tank for accurate calibration. Calibration adjusts the strapping table offset in the transmitter. The transmitter also ensures that the level value at the highest point will not exceed the HH Alarm level. If this point is reached the unit will not allow the operator to continue adjusting in that direction. If this condition is reached the strapping table will need to be adjusted. Please contact your distributor for the adjustment. Once the display is reading as accurately as possible the unit must be turned off and restarted for normal operation.

Fail Alarm Relay Output

The Fail Alarm is used to inform the operator when an error state exists in the system, a spill alarm has been set, or communications between the level transmitter and display has been interrupted (see Troubleshooting and Alarms sections for more information). This relay is a dry contact and can be set by the operator to either normally open or normally closed. It is factory set to normally open but may be changed by moving the Fail Alarm Relay Select Jumper (J10) to the other position. This relay is designed for fail safe operation (on when not in an alarm state, off when alarming). This relay is recommended for use in spill protection applications as a system fail relay and should be connected to a warning device, which can alert the operator that an error state is present.

Note: This relay is not designed to take the place of proper process supervision when filling the tank.

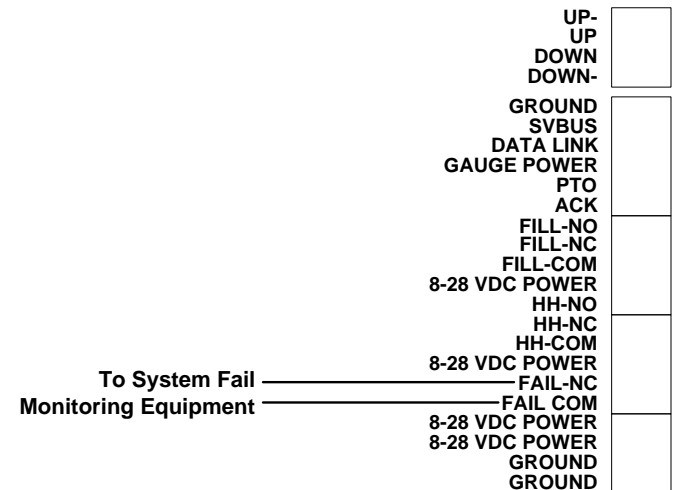
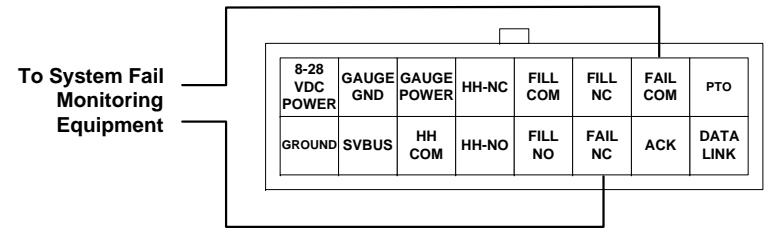

Fill Alarm Relay Output

The Fill alarm is a user set level intended to let the operator know when the level in the tank reaches a desired point. It is recommended that a horn or visible indicator be used on this output. The relay is factory set for fail safe operation (normally on, off in alarm state) but this can be changed by moving the Fill Alarm Relay Select Jumper (J1) to the other position. The Horn Circuit OK LED on the front of the display is connected to a circuit, which constantly monitors the output. As long as this sensing circuit is seeing a proper path on the output the LED will be on (if using the NC contact, for the NO contact the LED will be off when the circuit is correct). If the horn is too sensitive (makes peeping noises etc.) a resistor may need to be placed across the horn, this resistor should be approximately 300 ohms.

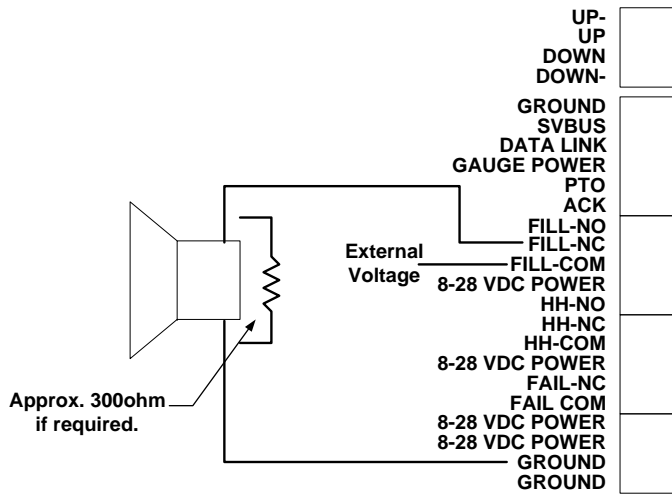
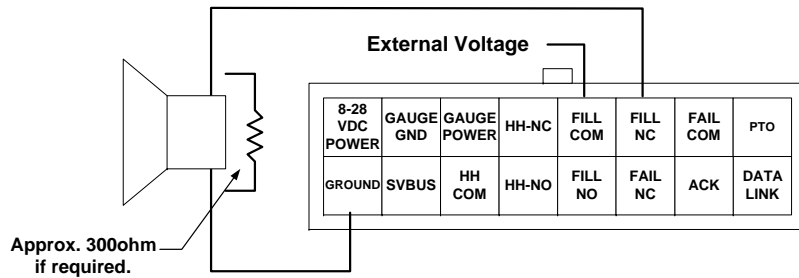

MODES OF OPERATION

Alarm Disable Mode

The finch display has a feature that allows the user to disable all of the alarms on the unit, while still having the unit keep active track of level. While in this mode display will show "oFF", as to notify the operator that his alarm functions are disabled. To view the current level of fluid while in this mode, the operator may press either button on the display to enter display mode, or turn on the PTO switch to return the display to an active state.



Display Mode

In this mode the Finch display will show the current tank level as well as any errors received from the level transmitter. The unit will remain in Display Mode for 30 seconds before it returns to Off Mode. If the Finch Display does not receive any information from the transmitter for 6 seconds the unit will display four dashes (----) to indicate a communications error.



Monitor Mode

In this mode the Finch Display shows the current level, any error messages, and any alarm information sent by the level transmitter. The unit will act on any alarms it receives. To enter Monitor Mode the PTO must be on. From Monitor Mode the operator can enter either Display Mode by turning off the PTO, or Set Fill / Fall Mode by pressing either button.

As with Display Mode the Finch Display will show the current level and if the level falls below 6" the unit will display 2 LO. If the display does not receive any information from the transmitter for 6 seconds the display will show four dashes (----) and set the Fail Alarm. The Fail Alarm will also be set if the Finch Display receives an error message or a Spill Alarm. The Fill / Fall Alarm and the HH Alarm are also active in this mode and will activate if the conditions are reached. For more information on the alarms please see the Alarms section of this manual.

Set Fill / Fall Mode

Set Fill / Fall Mode can be reached from either Display Mode or Monitor Mode by pressing either of the buttons on the face plate. If the Fill / Fall Jumper is out the display will blink FILL.



If the Fill / Fall Jumper is in the display will blink FALL. After a few seconds the display will show the current Fill or Fall setting. The current setting can then be adjusted up or down by pressing the appropriate button on the face plate. Each button press changes the level by one unit while holding the button down will change the level by tens of units. The fill level is prevented from exceeding the HH Level through software. After 5 seconds of inactivity the Finch Display will revert to either Display Mode or Monitor Mode depending of the state of the PTO.

High High Alarm Relay Output

The High High Alarm (HH) level is set in the strapping table which is loaded into the level transmitter. This level indicates a point 8" from the top of the tank. This point is important because the probe and transmitter begin to lose their linear accuracy at this point. This alarm is intended for use as a pump shutdown output to prevent the tank from being overfilled. This relay is normally on and in an alarm state it will turn off. For example: if the pump requires an open circuit to shut down the normally open contact should be used, the contact will be closed when not in an alarm state and will open in an alarm state. This alarm is set up this way for fail safe operation (if the display loses power it will automatically shut down the pump).

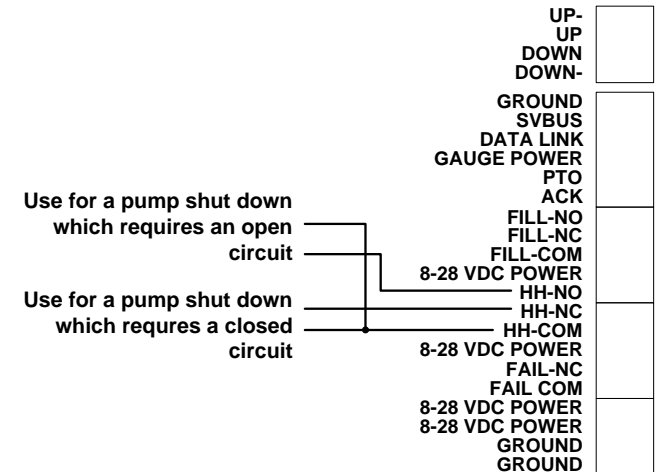
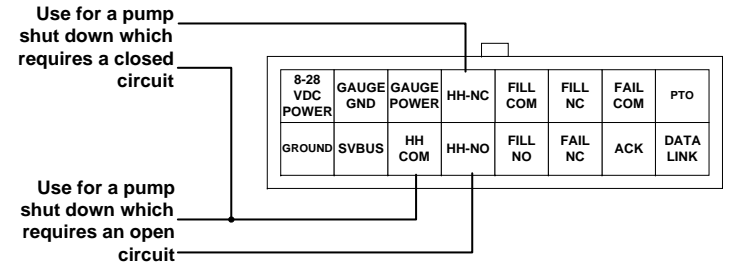

PTO and External Acknowledge

The PTO is used for setting the Finch Display to Monitor Mode. In Monitor Mode the Finch will display and act on all alarms sent by the level transmitter. To set the display to Monitor Mode the PTO needs to be shorted to ground through a PTO switch. If the unit is being used for a stationary system where power consumption is not a large concern the PTO may be jumpered directly to ground to keep the unit in Monitor Mode at all times. The external acknowledge is used to acknowledge alarms without having to use the buttons on the Finch Display.

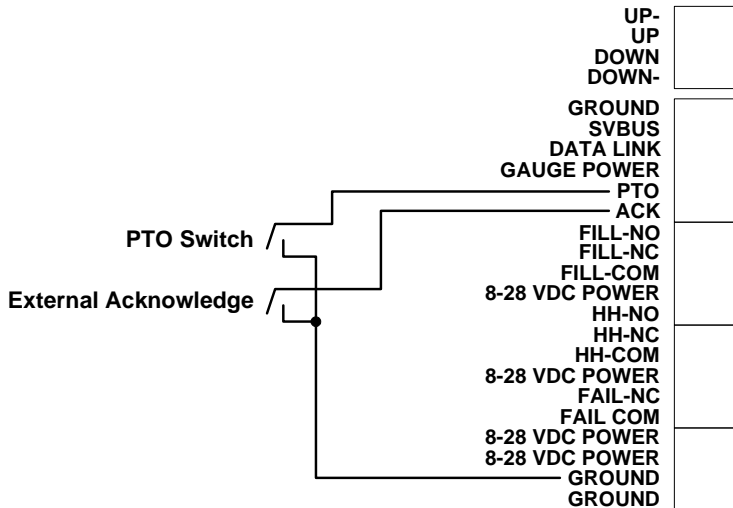
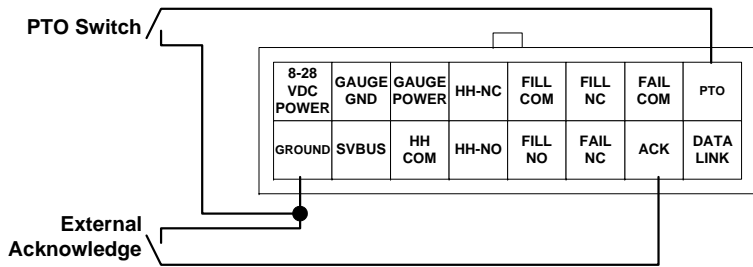

ALARMS

When the Finch Display is in Monitor Mode, the unit will respond to the various alarm states. There are four alarm states associated with three relays. The Spill and HH Alarms are controlled by the level transmitter only, the Fail alarm is controlled by the level transmitter primarily but may be set by the display if communications are lost, and the Fill / Fall Alarm is controlled by the Finch Display only. All alarm levels have a built in hysteresis to prevent false tripping during the load procedure. The Finch Display has a built in alarm log which will record each occurrence of a HH or Spill alarm. The Fill / Fall and Fail alarms are designed for fail safe operation, this means that should the Finch Display lose power the Fill and Fail relays will both go into their alarm states.

Note: The Finch Display will not allow the user to switch operating modes until all alarms have been acknowledged.

Fill / Fall Alarm

The Fill / Fall Alarm level is an operator entered value for use in filling or draining the tank to a predetermined level. This alarm is associated with the Fill Alarm Relay. The Fill Alarm Relay is a powered relay intended for use with a horn or visible indicator. When the fill / fall level is reached the alarm is set and the relay is activated. The Fill / Fall Alarm will persist until it is acknowledged. To acknowledge the alarm the operator needs to press one of the buttons on the front of the display or the External Acknowledge button (if installed).

High High Alarm

The High High Alarm (HH) level is set in the strapping table in the transmitter. This level is always set to 8" below the top of the tank, this is where the probe and transmitter begin to lose their linear accuracy. This alarm is associated with the HH Alarm relay, this relay is intended to be used as a pump shut down. When the HH Alarm trips the HH Alarm relay is activated, the display will begin flashing, alternating between the current level and HH, and the occurrence of the alarm is recorded in the alarm log. To acknowledge this alarm the operator must either press the External Acknowledge button (if installed) or press the buttons on the front in the following order: *up - up - down - up*. If the Fill / Fall Alarm and the High High Alarm are both set at the same time they can both be acknowledged at the same time by pressing the External Acknowledge button.

Fail Alarm

The Fail Alarm lets the operator know when a system error has occurred. This alarm is associated with the Fail Alarm relay. This alarm will activate the relay if an error message is received from the level transmitter, the Finch Display does not receive any communications for 6 seconds, or a Spill Alarm is set. This alarm is self resetting, when the cause of the alarm is gone so is the alarm. For example if the unit does not receive any communications for 6 seconds the alarm will be set, but if a communication is received 1 second later the alarm will reset itself. No acknowledgment is required for this alarm, nor is this alarm recorded in the alarm log.

Spill Alarm

The level for the Spill Alarm is set in the transmitter software. This level is set to approximately 6" from the top of the tank. This alarm has no relay associated directly with it but it is counted as a system error and therefore sets the Fail Alarm. When the Spill Alarm level is reached the display will flash Spill, and record the alarm in the alarm log.



The only way to reset the Spill alarm is to either pump out fluid until the level is below the HH Alarm level, or to put the unit into calibration mode, and cycle the power. If the Finch Display and level transmitter are not powered while the fluid is pumped out the Spill Alarm will *not* be reset.

Disabling the 2 LO Message

The Finch display can be set to measure below the bottom dead band by installing the 2 LO Disable Jumper. This will prevent the 2 LO message from appearing on the display, When installed this jumper will allow the Finch Display to give readings all the way to the shorting block.

Note: It is not recommended that the unit be operated in this state. The readings below the bottom dead band are being measured in the non-linear portion of the probe. These readings can not be counted on for accuracy.

WIRING

Transmitter Power and SVbus

Power for the TD80 Level Transmitter is provided through the Finch Display and the level is transmitted to the display through the SVbus.

